



INSTRUCTION MANUAL



TS-Series Warming Cabinets Installation - Operation - Maintenance



CAUTION

Read and understand all of the instructions and safety information in this manual before operating this product.

TABLE OF CONTENTS

Summary & Regulatory and Compliance Information	3
TS-Series Warming Cabinet Models	4
General Specifications	7
Main Features of a Typical Warming Cabinet	8
Warnings and Cautions	9
Unpacking Instructions	11
Installing TS-Series Warming Cabinets	12
Optional Direct Wiring Using Facility Power Supply	14
Basic Operation	15
The Touch Screen Interface	16
Quick Setup	17
<i>Create Accounts (Admin Task)</i>	17
User Login/Log Off	19
Navigation	19
Advanced Touch Screen Programming	20
<i>User Accounts (Admin Task)</i>	20
<i>Audit Trail</i>	21
<i>Notifications</i>	22
<i>Single and Dual Chamber Temperature Setting</i>	22
<i>Switching Temperature Units (Admin Task)</i>	23
<i>Data File Naming</i>	25
<i>Data Logging</i>	25
<i>Charts and Chart Setup</i>	27
<i>USB File Transfer</i>	30
<i>FTP/WAN Backup</i>	32
<i>Annotation</i>	33
<i>Digital Signatures</i>	34
<i>Alarm Function</i>	35
<i>E-mail Function</i>	36
<i>Communication Setting (Admin Task)</i>	38
<i>Clock Settings (Admin Task)</i>	39
<i>Language (Admin Task)</i>	40
<i>Offset Calibration (Admin Task)</i>	41
<i>Display Settings (Admin Task)</i>	42
<i>Configuration (Admin Task)</i>	43
<i>Exit Application (Admin Task)</i>	44
<i>Communications (Admin Task)</i>	45
<i>Using the Web Server</i>	48
<i>Using the VNC Server</i>	48
<i>Serial Communications Option</i>	52
Installing the Shelves	53
Patient Safety – Maximum Warming Temperature Limit	55
Unloading the Warming Cabinet	55
Cleaning Stainless Steel Warming Cabinets	56
Preventative Maintenance Checklist	57

Replacement Parts – General.....	58
Replacement Parts – Header Assembly and Electrical Drawer.....	59
Optional Cabinet Bases, Mobile Bases and Mobile Stands.....	61
Steel or Glass Door Hinge Reversal.....	62
Appendix A – System Security User Access List.....	72
Appendix B – Troubleshooting.....	74
TS-Series Electronic Connections Diagrams.....	76
Index.....	78
Preventative Maintenance Record.....	80
Notes.....	81
Limited Lifetime Warranty.....	83

Summary

DESCRIPTION OF PRODUCT

This manual covers the TS-Series (Touch Screen) blanket and fluid warming single and dual chamber cabinet units, manufactured for commercial use only.

PURPOSE OF THIS MANUAL

This manual is to provide the user instructions in the installation, operation and maintenance of the Touch Screen (TS) series warming cabinets.

This manual also contains general specifications, warnings and cautions.

Regulatory and Compliance Information

Safety Compliance

Main Standard(s):

UL 61010-1, 3rd Edition, May 11, 2012, Revised July 15 2015, CAN/CSA-C22.2 No. 61010-1- 12, 3rd Edition, Revision dated July 2015

From Country Differences:

- USA / Canada: UL 61010-1, 3rd Edition, 2012-05-11 / CAN/CSA-C22.2 No. 61010-1, 3rd Edition, 2012-05
- Switzerland: SN EN 61010-1:2010
- Japan: -
- Austria: EN 61010-1:2010
- Denmark: DS/EN 61010-1:2010
- Korea, Republic Of: K 61010-1
- Slovenia: SIST EN 61010-1
- Sweden: SS-EN 61010-1:2010
- United Kingdom: BS EN61010-1:2010

Additional compliances IEC IEC 61010-2-010 Safety requirements for electrical equipment for measurement, control, and laboratory use – Part 2-010: Particular requirements for laboratory equipment for the heating of materials.

Pollution degree rating: Pollution Degree 2 (UL 61010-1, 3rd edition). Rated for indoor, dry location use only.

Safety Class

Class I (PE connected)

Indications for Use:

MAC Medical, Inc. Blanket and Solution Warming Cabinets are designed to store and warm blankets, hospital linens, irrigation fluids and/or injection fluids in accordance with recommended warming temperatures and storage time guidelines provided by the manufacturers of such products. Rated for indoor, dry location use only.



TS-Series Warming Cabinet Models

Model #	Overall Size	Chambers	Door Type	Door Hinge	Base Style	Other Options
SWC182424-TS	20.5"D x 24"W x 24.5"H	Single	G=Glass Door Blank=Stainless Steel Door (Standard)	LH=Left Hinge Blank = Right Hinge (Standard)	†2B = 2" Base	220 = 220/240V Power Supply C = Celsius R1 = Recessed Unit with Insulation Wrap, no Top Panel, no Side Panels and no Trim Kit. R2 = Recessed Unit with Top Panel, Side Panels, and Trim Kit. SB = Seismic Braces WB = Roll Out Basket P = Pass Through Chamber ST = Sloped Top ‡‡EL = Electronic Keypad Lock
SWC242424-TS	26.5"D x 24"W x 24.5"H	Single				
SWC183024-TS	20.5"D x 30"W x 24.5"H	Single				
SWC243024-TS	26.5"D x 30"W x 24.5"H	Single				
SWC182436-TS	20.5"D x 24"W x 36"H	Single				
SWC183036-TS	20.5"D x 30"W x 36"H	Single				
SWC242436-TS	26.5"D x 24"W x 36"H	Single				
SWC243036-TS	26.5"D x 30"W x 36"H	Single				
SWC182464-TS	20.5"D x 24"W x 64.75"H	Single				
SWC242464-TS	26.5"D x 24"W x 64.75"H	Single				
SWC183064-TS	20.5"D x 30"W x 64.75"H	Single				
SWC243064-TS	26.5"D x 30"W x 64.75"H	Single				
SWC182474-TS	20.5"D x 24"W x 74.5"H	Single				
SWC183074-TS	20.5"D x 30"W x 74.5"H	Single				
SWC242474-TS	26.5"D x 24"W x 74.5"H	Single				
SWC243074-TS	26.5"D x 30"W x 74.5"H	Single				
DWC182464T-TS*	20.5"D x 24"W x 64.75"H	Dual				
DWC242464T-TS*	26.5"D x 24"W x 64.75"H	Dual				
DWC183064T-TS*	20.5"D x 30"W x 64.75"H	Dual				
DWC243064T-TS*	26.5"D x 30"W x 64.75"H	Dual				
DWC182474T-TS*	20.5"D x 24"W x 74.5"H	Dual				
DWC242474T-TS*	26.5"D x 24"W x 74.5"H	Dual				
DWC183074T-TS*	20.5"D x 30"W x 74.5"H	Dual				
DWC243074T-TS*	26.5"D x 30"W x 74.5"H	Dual				
DWC182474E**TS	20.5"D x 24"W x 74.5"H	Dual				
DWC183074E-TS**	20.5"D x 30"W x 74.5"H	Dual				
DWC242474E**TS	26.5"D x 24"W x 74.5"H	Dual				
DWC243074E-TS**	26.5"D x 30"W x 74.5"H	Dual				

†Only available for Dual Chamber Units
‡‡Only available for Single Chamber Units

* = Chambers in Thirds

** = Equal Chambers

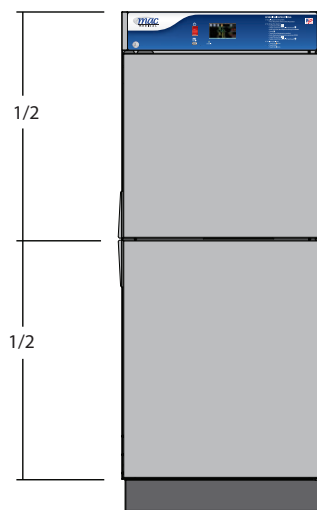
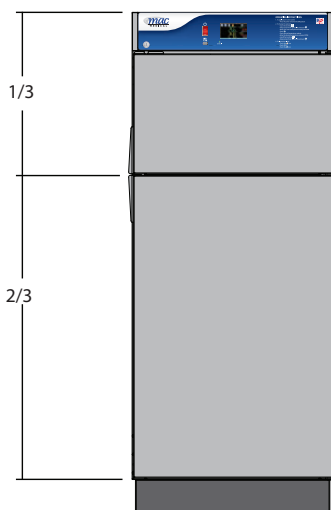

Sloped Top

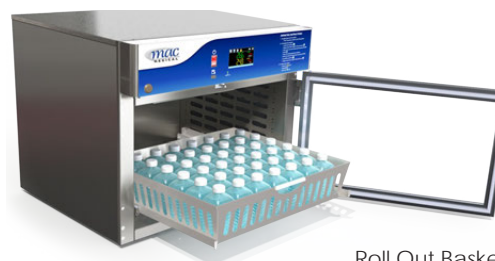

Roll Out Basket

Interior Dimensions, Cubic Foot Capacity

Model #	Upper or single Chamber (h x w x d) in inches	Middle Chamber (h x w x d) in inches	Lower Chamber (h x w x d) in inches	Cubic Foot Capacity Upper or single Chamber	Cubic Foot Capacity Middle Chamber	Cubic Foot Capacity Lower Chamber
SWC182424-TS	15.25 x 20.0 x 17.0	n/a	n/a	3.0	n/a	n/a
SWC242424-TS	15.25 x 20.0 x 23.0	n/a	n/a	4.06	n/a	n/a
SWC183024-TS	15.25 x 26.0 x 17.0	n/a	n/a	3.9	n/a	n/a
SWC243024-TS	15.25 x 26.0 x 23.0	n/a	n/a	5.27	n/a	n/a
SWC182436-TS	25.0 x 20.0 x 17.0	n/a	n/a	5.0	n/a	n/a
SWC183036-TS	25.0 x 26.0 x 17.0	n/a	n/a	6.39	n/a	n/a
SWC242436-TS	25.0 x 20.0 x 23.0	n/a	n/a	6.70	n/a	n/a
SWC243036-TS	25.0 x 26.0 x 23.0	n/a	n/a	8.65	n/a	n/a
SWC182464-TS	49.5 x 20.0 x 17.0	n/a	n/a	9.74	n/a	n/a
SWC242464-TS	51.0 x 20.0 x 23.0	n/a	n/a	13.60	n/a	n/a
SWC183064-TS	51.0 x 26.0 x 17.0	n/a	n/a	13.05	n/a	n/a
SWC243064-TS	51.0 x 26.0 x 23.0	n/a	n/a	17.65	n/a	n/a
SWC182474-TS	61.0 x 20.0 x 17.0	n/a	n/a	12.00	n/a	n/a
SWC183074-TS	61.0 x 26.0 x 17.0	n/a	n/a	15.60	n/a	n/a
SWC242474-TS	61.0 x 20.0 x 23.0	n/a	n/a	16.24	n/a	n/a
SWC243074-TS	61.0 x 26.0 x 23.0	n/a	n/a	21.1	n/a	n/a
DWC182464T-TS*	13.5 x 20.0 x 17.0	n/a	24.5 x 20.0 x 17.0	2.65	n/a	4.82
DWC242464T-TS*	13.5 x 20.0 x 23.0	n/a	24.5 x 20.0 x 23.0	3.59	n/a	6.52
DWC183064T-TS*	13.5 x 26.0 x 17.0	n/a	24.5 x 26.0 x 17.0	3.45	n/a	6.27
DWC243064T-TS*	13.5 x 26.0 x 23.0	n/a	24.5 x 26.0 x 23.0	4.67	n/a	8.48
DWC182474T-TS*	15.25 x 20.0 x 17.0	n/a	34.5 x 20.0 x 17.0	2.65	n/a	6.79
DWC242474T-TS*	15.25 x 20.0 x 23.0	n/a	34.5 x 20.0 x 23.0	4.06	n/a	9.18
DWC183074T-TS*	15.25 x 26.0 x 17.0	n/a	34.5 x 26.0 x 17.0	3.45	n/a	8.82
DWC243074T-TS*	15.25 x 26.0 x 23.0	n/a	34.5 x 26.0 x 23.0	5.28	n/a	11.93
DWC182474E-TS**	25.0 x 20.0 x 17.0	n/a	26.0 x 20.0 x 17.0	4.97	n/a	5.24
DWC183074E-TS**	25.0 x 26.0 x 17.0	n/a	26.0 x 26.0 x 17.0	6.39	n/a	6.65
DWC242474E-TS**	25.0 x 20.0 x 23.0	n/a	26.0 x 20.0 x 23.0	6.65	n/a	6.99
DWC243074E-TS**	25.0 x 26.0 x 23.0	n/a	26.0 x 26.0 x 23.0	8.65	n/a	8.99

Usable Chamber Space

The usable chamber space of the single, dual and triple cabinets is slightly different from the height, width and depth interior dimensions in the table on the previous page.

Note that the usable chamber inner height is measured from the bottom of the air box to the bottom of the chamber.

(In these views, the doors were removed for clarity.)

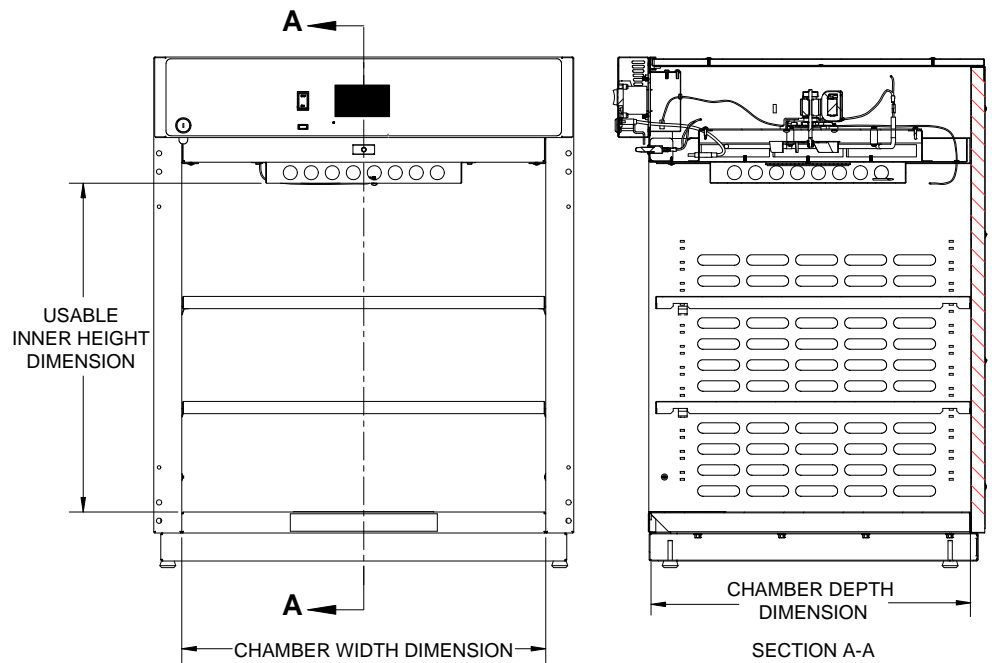

Fig. 1: Single Chamber Unit Usable Space

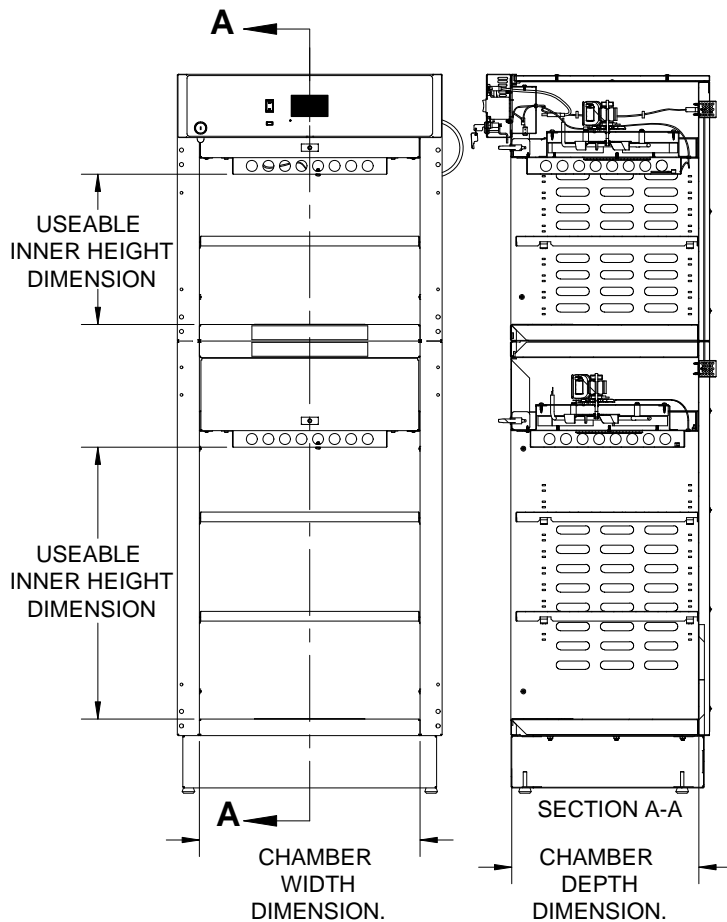

Fig. 2: Dual Chamber Unit Usable Space

General Specifications

Cabinet Construction and Material

- 300 Stainless Steel (all panels, header and doors) double-walled construction with insulation. Doors are double pane stainless steel.
- Fully insulated to provide uniform heating
- Optional Glass door are double paned tempered glass framed with aluminum.
- Doors are fully gasketed and hinged on right side or optionally on the left side.

Factory Presets

- All units are preset to measure temperature in Fahrenheit (unless the unit was specifically ordered to be preset for Celsius.)

Power Requirements

- 120 VAC, 60 Hz, Single Phase, 15 AMP, Ground Fault Interrupter Circuit (GFI) protected electrical outlet, or 220 VAC, 60 Hz, Single Phase, 7 AMP, GFI protected electrical outlet (by others) installed per local building codes and provides protective earth.
- Cabinets are supplied with a 7 foot (2.3 m) long, 14-3 SJT power cord with a 120V (NEMA 15P) hospital grade plug. For multi-chambered units, ON/OFF switches are supplied for each chamber.
- All individual electronic components are Underwriter's Laboratory (UL) approved and recognized.

Power Specifications are located on the unit identification rating tag (Fig. 3), which is permanently attached on the inside of the door or on the back of the upper chamber.

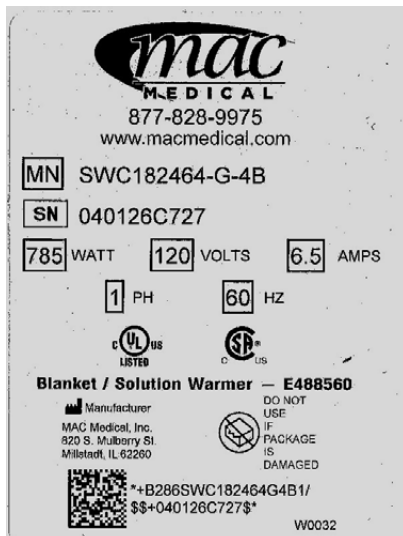

Fig. 3: Power specification label

Electrical Specifications by Model	
Model #	Description
SWC182424-TS	120V, 2.9 Amp, 50/60 Hz, .23 kWh (Avg.), 785 BTU/hr (Avg.)
SWC182436-TS	120V, 5.7 Amp, 50/60 Hz, .23 kWh (Avg.), 785 BTU/hr (Avg.)
SWC242424-TS, SWC242436-TS, SWC243024-TS, SWC243036-TS	120V, 6.3 Amp, 50/60 Hz, .45 kWh (Avg.), 1535 BTU/hr (Avg.)
SWC183024-TS, SWC183036-TS	120V, 5.7 Amp, 50/60 Hz, .45 kWh (Avg.), 1535 BTU/hr (Avg.)
SWC182464-TS, SWC182474-TS, SWC183074-TS, SWC242474-TS, SWC243074-TS	120V, 6.5 Amp, 50/60 Hz, .47 kWh (Avg.), 1604 BTU/hr (Avg.)
SWC183064-TS	120V, 6.3 Amp, 50/60 Hz, .41 kWh (Avg.), 1400 BTU/hr (Avg.)
SWC242464-TS, SWC243064-TS	120V, 6.5 Amp, 50/60 Hz, .41 kWh (Avg.), 1604 BTU/hr (Avg.)
SWC182464-TS, SWC182474-TS, SWC183074-TS, SWC242474-TS, SWC243074-TS,	120V, 6.5 Amp, 50/60 Hz, .47 kWh (Avg.), 1604 BTU/hr (Avg.)
DWC183064T-TS, DWC242464T-TS	120V, 8.3 Amp., 50/60 Hz, .60 kWh (Avg.), 2047 BTU/hr (Avg.)
DWC182474E-TS, DWC242474E-TS, DWC182464T-TS, DWC182474T-TS, DWC243064T-TS, DWC242474T-TS	120V, 8.9 Amp., 50/60 Hz, .65 kWh (Avg.), 2218 BTU/hr (Avg.)
DWC183074T-TS	120V, 8.3 Amp. 50/60 Hz, .82 kWh (Avg.) 2047 BTU/hr (Avg.)
DWC183074E-TS	120V, 11.4 Amp. 50/60 Hz, .82 kWh (Avg.) 2798 BTU/hr (Avg.)
DWC243074T-TS	120V, 12.5 Amp. 50/60 Hz, .90 kWh (Avg.) 3071 BTU/hr (Avg.)
DWC243074E-TS	120V, 12.9 Amp. 50/60 Hz, .90 kWh (Avg.) 3071 BTU/hr (Avg.)

Main Features of a Typical Warming Cabinet

(Single Chamber Cabinet shown here)

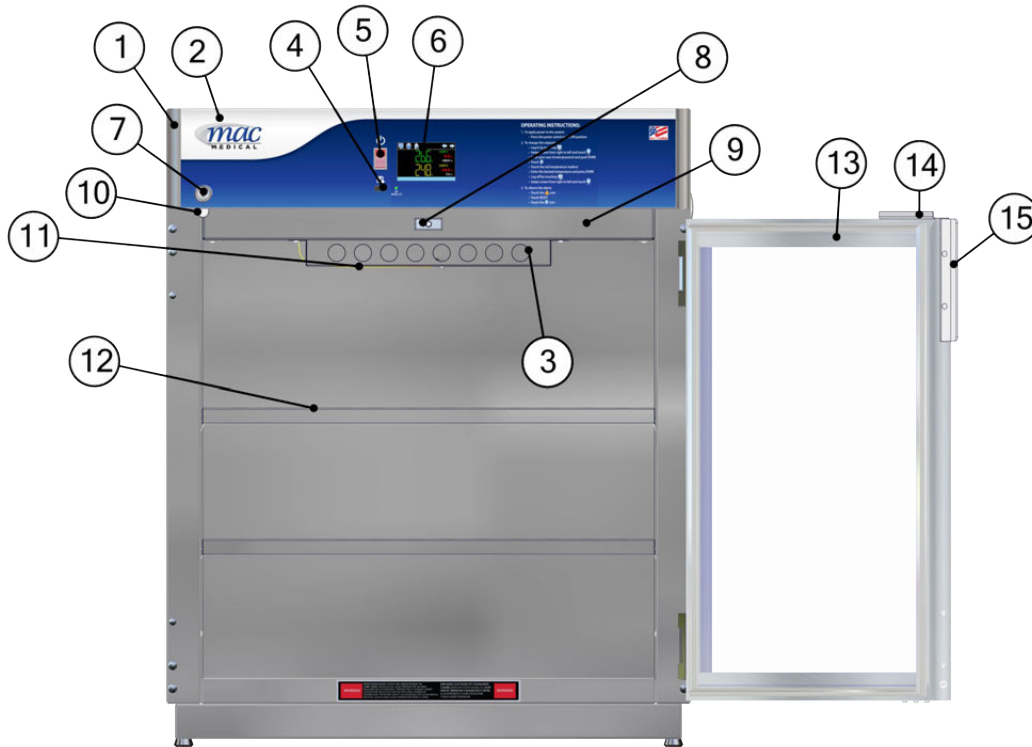









Fig. 4: Warmer Cabinet Main Features

This list shows the main elements of a warming cabinet. For a list of replacement parts with their part numbers and quantities, see "Replacement Parts – General" on page 58 and "Replacement Parts – Header Assembly and Electrical Drawer" on page 59.

Item #	Description	Qty
1	Header Assembly (24" and 30")	1
2	Overlay (24" and 30") TS-series	1
3	Air Box	1 per chamber
4	USB Cable Plug	1
5	On/Off Switch	1
6	Touch Screen Display Board	1
7	Key Lock	1
8	Door Switch	1 per chamber
9	Drawer Assembly	1 per chamber
10	Cam Lock Latch	1 per door
11	Probe J Type Thermocouple	1 per chamber
12	Adjustable Perforated Shelf	As Required
13	Door (glass or steel)	As Required
14	Cam Lock Plate	1 per door
15	Handle	1 per door

Warnings and Cautions

The following is a list identifying the various warning and caution icons used in this manual.

Icon Type	Icon	Description
Warnings		(Red triangle with an exclamation point) indicates the potential for minor to severe injuries up to and including death to personnel.
Cautions	 	(Yellow triangle with an exclamation point) indicates the potential for minor injury to personnel and damage to equipment. Note: The exclamation point will not be visible where only equipment damage is present.
Burn Hazard Warnings		(Yellow triangle with radiating lines) indicates a potential burn injury to personnel.
Electrical Warnings		(Yellow triangle with a lightning bolt) indicates a possible shock hazard is present. Severe shock hazards shall be a lightning bolt in a red triangle.
Explosion Hazard		(Yellow triangle with the explosion icon) indicates the equipment should not be operated in areas where explosions could occur.
Fire Hazard		(Yellow triangle with the fire icon) indicates the warning cabinet should not be loaded with materials or liquids that are flammable or use in the presence of flammable anesthetics or solvents.

The following is a list of safety precautions that must be observed when operating this equipment.

 **Warning – Injury Hazard**

REPAIRS AND ADJUSTMENTS should be attempted only by experienced service representatives. Use of unqualified persons to work on this equipment could result in personal injury or costly damage.

 **Warning – Burn Hazard**

- Do NOT use in the presence of flammable anesthetics.
- Do NOT heat liquids in the presence of flammable solvents.
- Failure to observe this Warning can result in severe personal injury and even death.

 **Warning – Burn Hazard**

- Do NOT exceed 150°F (65.56°C) for non-vented closures: screw caps, crimp seals, plastic pouches, etc. Do not exceed pre-sterile solution manufacturer's temperature requirements.
- Do NOT raise set temperature to increase rate of heating. Allow approximately 4-6 hours for solutions to reach desired temperatures.
- Do NOT use liquids on or inject into living tissue, unless actual liquid temperature has been measured and is acceptable. Temperature of the warming cabinet's contents may be hotter than the displayed air temperature. For patient safety, in accordance with good medical practice, always check liquid temperature prior to using.

 **Warning – Electric Shock Hazard**

Do NOT remove control tray. Contact a qualified service representative. Some of the troubleshooting procedures can require access to live electrical circuitry. Dangerous accidental contact with line voltage is possible. Only qualified service personnel should be allowed to perform these procedures.

 **Warning – Explosion Hazard or**  **Fire Hazard**

- Do NOT warm flammable materials or liquids.
- Do NOT use in the presence of flammable anesthetics.
- Do NOT heat liquids in the presence of flammable solvents.

 **Caution – Possible Equipment Damage**

Some items are not acceptable in these warming cabinets. If in doubt as to whether an item can be safely processed, have the facility supervisor contact the manufacturer of the item.

 **Caution: Repairs and Adjustments** should only be attempted by experienced service personnel who are fully acquainted with this equipment. Use of unqualified or inexperienced personnel to work on the equipment, or the installation of unauthorized parts, could result in serious personal injury or costly damage. Always unplug power cord from power source before attempting any repairs or servicing this equipment.

Special User Attention

Prior to use, all personnel who will operate the Warming Cabinet must be instructed in the correct usage and operation. All personnel who will use the Warming Cabinet should be aware that sensible care must be exercised to maintain patient safety and to keep the Warming Cabinet performing at peak efficiency.

Intended Use Notice

This product is intended to be used by medical personnel for the purpose of providing heated storage of blankets, sterile water and saline solutions used in the care of patients in surgery, recovery, OB/GYN, ICU, ER and trauma areas in healthcare facilities where all operators are instructed on the usage, limitations and hazards. No other use is authorized or recommended.

This product is to be used strictly for the purpose for which it was designed. Using this product in a manner not specified by MAC Medical, Inc. can void the protection provided by the equipment manufacturer. MAC Medical, Inc. disclaims all liability for the consequences of this product being used for other than what it was designed for. Product modification or misuse can be dangerous. MAC Medical, Inc. disclaims all liability for the consequences of product alterations or modifications, as well as for the consequence that can result from the combination of this product with other products, whether supplied by MAC Medical, Inc. or by other manufacturers, unless such a combination has been specifically endorsed, in writing, by MAC Medical, Inc.

Unpacking Instructions

Receiving Requirements

The customer is responsible for making sure the loading dock at their facility can accommodate a shipping carton approximately 70 inches (1.778 m) long and 40 inches (1.016 m) wide.

The customer must also provide transportation equipment (forklift, etc) for a carton weighing approximately 500 lb (227 kg).

Inspection

1. Receiving area must meet all State and Local regulations prior to unpacking.
2. Customer must inspect carton both before and after unpacking to determine if any items were damaged during shipping.
 - A. All damaged items must be listed on the Bill of Lading.
 - B. The serial number and model number shown on the carton label must match the numbers on the Bill of Lading and the Invoice.
3. Customer is responsible for the proper disposal of all packing materials. The disposal of these items must meet all State and Local regulations.

Unpacking the Warming Cabinet

Retain all shipping materials until warming cabinet is completely unpacked and inspected for damage.

1. Remove metal bands holding the bottom and top of the shipping carton together.
2. Remove all metal staples holding the top and bottom of the carton to its sides.
3. Remove the top of the carton.
4. Remove metal staples making the flaps around the top edge of the carton.
5. Remove metal staples attaching the sides of the carton to the bottom of the carton.
6. Remove the sides of the carton by lifting them straight up from the bottom tray.
7. Lift Warmer straight up from bottom tray of the shipping carton and remove it.

8. Remove all protective packing material
 - A.  **Caution:** DO NOT use a box cutter or any other cutting utensil to remove the plastic protective wrapping around the Warming Cabinet. These items can scratch the protective coating on the stainless steel, allowing the surface to rust.
9. The Warming Cabinet is now ready for use.
10. Discard shipping and packing materials in compliance with Local and State regulations.
11. Warmers, when not in use, must NOT be double-stacked while in storage. Warmers, while still in shipping cartons must NOT be double-stacked when not in use.



Fig. 5: Warming Cabinet in Shipping Container

Installing TS-Series Warming Cabinets

Environmental Conditions

This unit is intended for use in a stable ambient environment, with an ideal temperature of 72°F (22.22°C) or less. The unit should never be used directly next to any appliance that may produce heat, such as an autoclave.

During Transport and Storage (in original packaging materials)

- Ambient Temperature: -40° - 159°F (-40° - 70°C)
- Relative Air Pressure: 10% - 100%, including condensation
- Air Pressure: 500 hPa (14 inHg - 31.3 inHg)

During Use – for Dry Locations

- Ambient Temperature: 60° - 85°F (15° - 30°C)
- Relative Air Moisture: 30% - 60% non-condensing
- Air Pressure: 700 hPa - 1060 hPa (20.7 inHg - 31.3 inHg)

Surge Protection

Due to the sensitive nature of the Touch-Screen processor, MAC Medical recommends that a surge protector be used when attaching the unit to a power source.

Installation

Before starting the installation, review the local electric codes including the Occupational Health and Safety Act for any requirements pertaining to the proper installation of this equipment.

Contact your MAC Medical representative for seismic calculations and tie-down hardware, if applicable.

1. Carefully uncrate the TS-Series Warming Cabinet.
2. Inspect for any damage. If there is damage, please contact MAC Medical, Inc. at 1-877-828-9975.
3. Check your 120V, 60 Hz, Single Phase 15 AMP GFCI Protected electrical outlet or 220V, 60 Hz, Single Phase, 7 AMP GFCI Protected electrical outlet. Be sure the outlet is safely accessible and in proper working condition.
4. Plug the 3-prong electrical plug into the 120 VAC, 60 Hz, 15 AMP, GFCI Protected Outlet or a 220 VAC, 60 Hz, Single Phase, 7 AMP GFCI protected

electrical outlet. Make sure the electrical outlet is safely accessible and in proper working condition.

5. Place Warming Cabinet on a solid, level platform where external movement will not interfere with loose contents used by the warmer. Use the Leg Levelers (installation detailed on page 13) to level the cabinet once it is placed.
6. Make sure the shelving is correctly located as desired and level. If not, adjust their height (see "Adjusting the Shelves" on page 53).
7. Before use, remove any items that have been stored in the cabinet.

Testing before Using

All warming cabinets have been calibrated and tested before leaving the factory. There is no need for the user to do additional testing after installation prior to use.

After six months of use, it is recommended that the user test the warming cabinet for temperature accuracy. See "Preventative Maintenance Checklist" on page 57.

Header Overlay Coating is PERMANENT

The header overlay DOES NOT have a peelable protective cover. The protective coating on the header overlay is PERMANENT!

**DO NOT ATTEMPT TO PEEL
PROTECTIVE COATING FROM
HEADER OVERLAY!**



Attempting to remove the protective coating may result in voiding the manufacturers warranty.

Installing Warming Cabinet Leg Levelers

Warming Cabinets are shipped with four Leg Levelers that must be installed by the customer (Fig. 6).

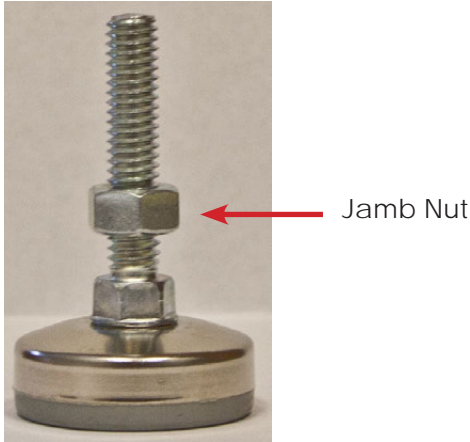

Fig. 6: Leg Leveler

The Warming Cabinet base has four holes into which the Leg Levelers can be installed (Fig. 7).



Fig. 7: Holes in Cabinet base

Working with at least two people, carefully tilt the Warming Cabinet back slightly and insert the four Leg Levelers up into the four provided holes (Fig. 8).

IMPORTANT: The Jamb Nut must go on the outside of the Cabinet Base, not the inside. Figure 9 shows a Leg Leveler correctly installed with the Jamb Nut outside the base. Figure 10 shows the Leg Leveler incorrectly installed with the Jamb Nut inside the base.



Fig. 8: Insert Leg Leveler into base

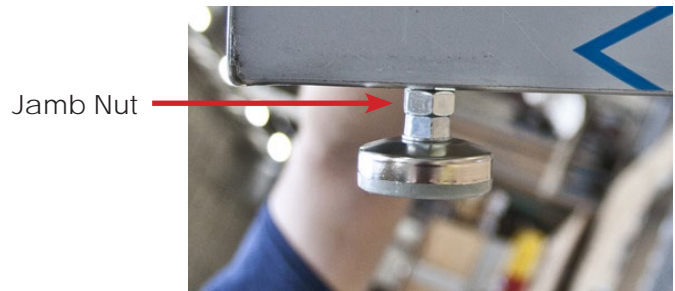

Fig. 9: Leg Leveler - Correct installation

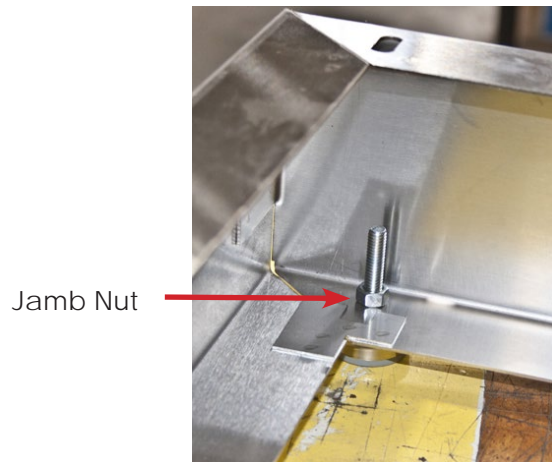

Fig. 10: Leg Leveler - Incorrect installation

Optional Direct Wiring Using Facility Power Supply

⚠ NOTE: The following procedure must be performed by a qualified electrical technician to avoid personal injury or damage to the unit.

Warming Cabinets can be wired directly into the facility's wiring by following these steps:

1. Remove four 8 X 1-5/8" self tapping screws and lift off the Top Outer Panel (Fig. 11).
2. Remove two 8 X 1/2" self tapping screws and lift off the Top Inner Panel (Fig. 11).
3. Loosen the 3/8" straight-through connector (Fig. 12, Item 1) and disconnect wiring from terminal board (Fig. 12, Item 5) and from Items 2, 3 and 4 in Figure 12.
4. Remove existing power cable (Fig. 12, Items 2, 3, and 4) from terminal block and pull out of Warming Cabinet through 3/8" connector (Fig. 12, Item 1).
5. Feed facility wiring cable back through the 3/8" connector (Fig. 12, Item 1) in the back of the cabinet and wire onto terminal board as shown in Figure 12. Tighten the 3/8" connector to securely hold the facility wiring in place.
6. On the terminal board, the green wire (Item 4) connects with the green ground wire.
7. The white wire (Item 3) connects opposite with the white wire, or neutral wire, on the terminal board.
8. The black wire (Item 2) connects opposite of the black or positive wire on the terminal board.
9. Reinstall the Inside Top Panel using two 8 X 1/2" self-tapping screws (Fig. 11).
10. Reinstall the Outside Top Panel using four 8 X 1-5/8" self-tapping screws (Fig. 11).
11. Carefully slide the unit into its permanent location.

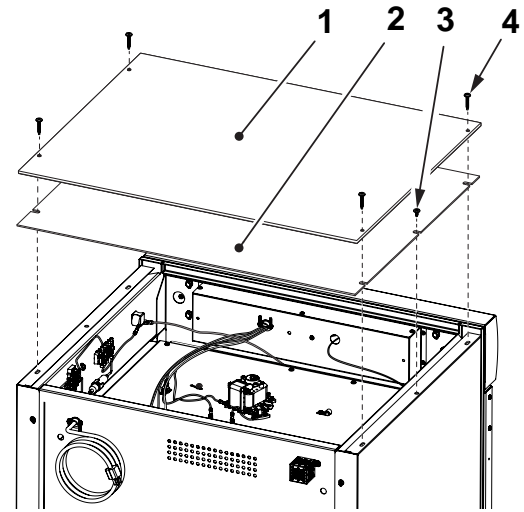

Fig. 11: Remove Top Covers

Item	P/N	Description	Qty
1	SMW0027	Outside Top Panel	1
2	SMW0028	Inside Top Panel	1
3	H0012-01	Screw, Self-Tapping, 8 X 1/2"	2
4	H0012-02	Screw, Self-Tapping, 8 X 1-5/8"	4

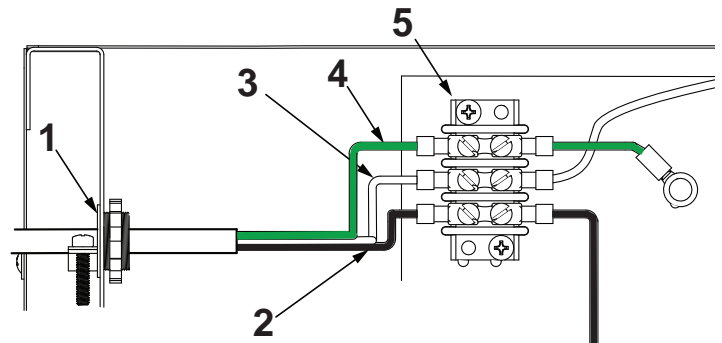

Fig. 12: Unwiring Terminal Block

Item	P/N	Description	Qty
1	W0140	Connector, Straight, 3/8"	1
2	W0077	Wire, Black, Positive	1
3	W0077	Wire, White, Neutral	1
4	W0077	Wire, Green, Ground	1
5	W0005	Terminal Strip, 3-Position	1

Basic Operation

This cabinet has been designed to heat:

- Liquids in vented containers
- Liquids in non-vented containers to a temperature of 150°F maximum (65.6°C)
- Metal objects
- Muslin or 100% cotton sheets and wool blankets
- Glass containers – annealed borosilicate glass (Pyrex type) only
- Plastic containers - rated **Thermal** and capable of withstanding temperatures in excess of 300°F (149°C) only

DO NOT WARM

- Synthetic blend fabrics
- Flammable liquids
- Items containing non-thermal plastic, rubber, metal snaps, studs, hooks, etc.

Recommended Settings

MAC Medical, Inc. does not recommend chamber set points for any items that are to be warmed. For appropriate heating temperatures, please contact the item manufacturers. For more information, please contact MAC Medical, Inc.

For blankets, follow blanket manufacturer's instructions for the set point.

For intravenous and irrigation fluids, follow temperature guidelines printed on the container or contact your supplier for temperature and expiration periods.

Loading Contents in Cabinet

Load contents into the chamber with a minimum of 1 inch of space between all walls and fan to allow for evenly distributed circulation (as seen here).

Allow 1 inch of spacing between fluid containers for evenly distributed heating (Fig. 13). Avoid stacking fluid bags as this increases the heating time required to achieve set temperatures.

Blankets must be folded and stacked to allow a 1 inch minimum space from the sides, back and top of the compartment or the shelf above. Do not let blanket protrude past the front edge of the shelf.

DO NOT OVERLOAD.

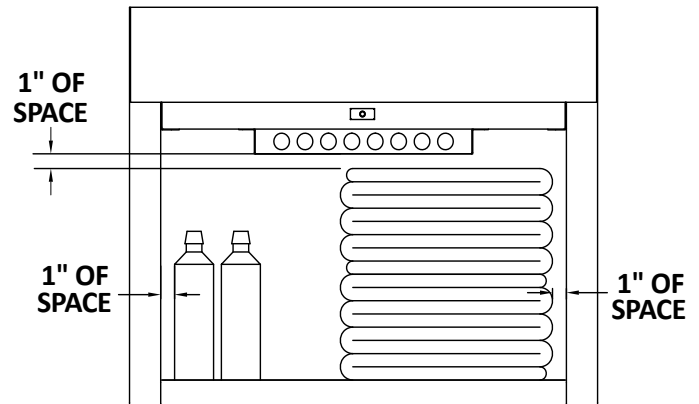

Fig. 13: Content Spacing

Once a set temperature is selected and obtained, it will be controlled throughout the operations within $\pm 1^\circ\text{F}$ to 3°F (1.7°C to -1.6°C) of the selected temperature.

From a cold start, each compartment's loaded contents will be evenly heated to a set point within 2 to 6 hours (depending on the load). In the event of power loss, the warmer will resume normal function once power is restored.

For multi-chambered units, each chamber can be loaded with different goods and set at different temperature settings.

In Case of Power Failure

In case of power failure, the unit will resume normal operation when power is restored.

Follow the fluid manufacturer's guidelines for unused solutions that have cooled or have been removed from heated storage.

The Touch Screen Interface

The Touch Screen display is split into two sections: the icon bar and main display area.

Icon Bar



Main Display

Fig. 14: Touch Screen Explanation



The menu icon will open the main menu for navigating to the different control and monitoring screens. Menu items will dynamically appear, providing available options based on the system area the user is in, i.e., security, data logging, setup, etc.



The information (help) icon will display text-based help associated with the current screen. Help is available in 28 languages based on the user selection in the offline setup section of Touch Screen.



The home icon will return the user to the main view from anywhere in the Touch Screen application. The main view is set by the OEM in the Touch Screen configuration and can be the single or dual loop, chart, alarm, alarm history, event or digital IO view.



The alarm icon will appear and flash when a new system alarm occurs. Pressing the alarm icon will take the user directly to the alarm monitor screen in order to view and/or reset the active alarm condition.



The left and right navigation arrows will appear on screens that provide additional information that the user can scroll to such as the loop view screens, charts or program entry screen in order to cycle through each step of a ramp/soak program.

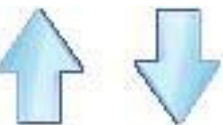

The up and down navigation arrows will appear on screens that provide list views in order to scroll up and down through items of the list. List views also provide “touch sliding” like other modern smart devices.

Note: A single press of the left/right or up/down arrows will scroll list views to the next list item, program steps to the next step or screens to the next available loop or chart. Pressing and holding the arrow keys will continue the item scrolling until the end of the list is reached or the button is released.

Important: Do not use any sharp or metal objects on the touch screen as they may damage the surface. Also be sure that hands and fingers are free from oils or chemicals, which may mar the surface of the touch screen.

Quick Setup

Create Accounts (Admin Task)

Note: Preconfigured Administrator only utilities are flagged as (Admin Task) throughout the programming sections of this manual and will require an additional log in to access the utility. The administrator can later assign user rights to these utilities as needed.

Switch On

1. Plug the three-prong electrical plug into the 120 VAC, 60 Hz, 15 AMP, GFC Protected Outlet or a 220 VAC, 60 Hz, Single Phase, 7 AMP GFC protected electrical outlet. Make sure the electrical outlet is safely accessible and in proper working condition.
2. Switch on the Warming Cabinet by pressing in the ON side of the ON/OFF switch. Touch screen will light up for use (Fig. 15).

Set up Default Supervisor Account

When using the Warming Cabinet for the first time, a default supervisor must be set up and logged in.

NOTE: When setting up accounts through the set up process, every entry must be minimum of five characters.

3. Default Supervisor Account Setup: Press HOME, then MONITOR icons. Swipe the screen left to right to go to the LOGIN icon (Fig. 16). Press this icon to open the log in module.
4. A keyboard screen appears next. Touch USER box and enter default supervisor name "Super" (Fig. 17).
5. Touch the PWD box and enter default password "1-2-3-4-5" (Fig. 17). Password displays as *****. Press DONE.
6. Supervisor login confirmation appears. Press OK (Fig. 18).

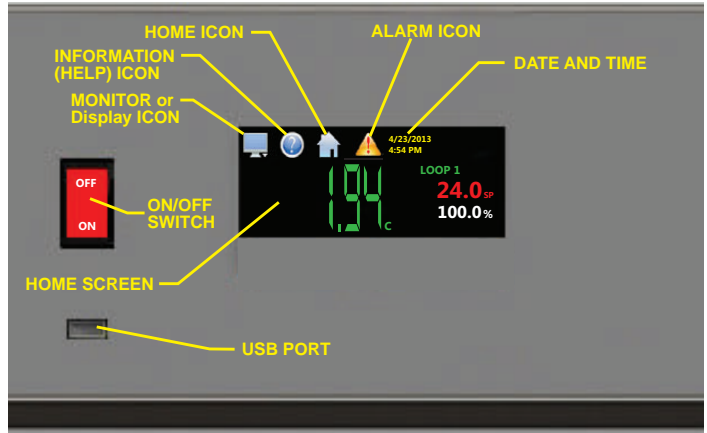

Fig. 15: TS Series Controller Interface Screen

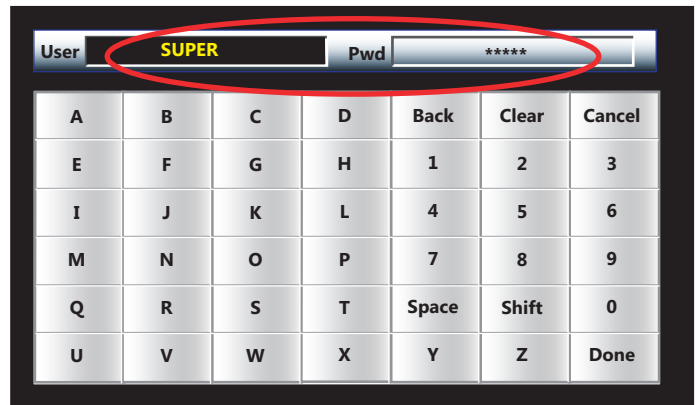

Fig. 17: Enter Default Supervisor in Keyboard

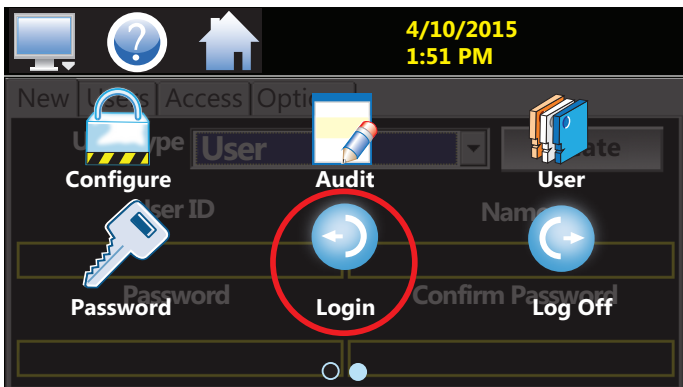

Fig. 16: Select Login Icon

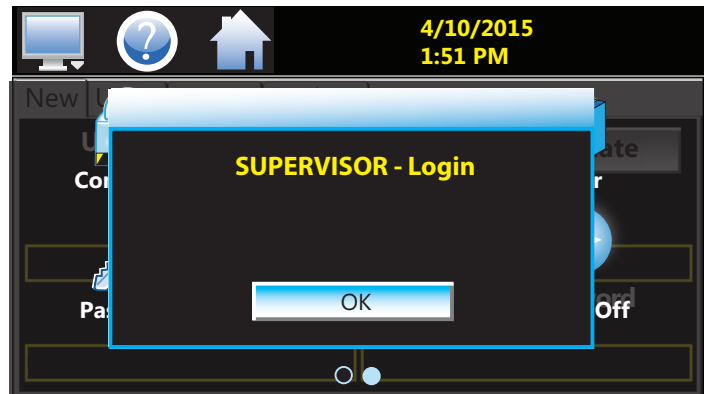

Fig. 18: Supervisor Login Confirmation

Set up Personal Supervisor Account: After setting up the default supervisor account and logging in, next set up a personal supervisor account from which you can then create user accounts.

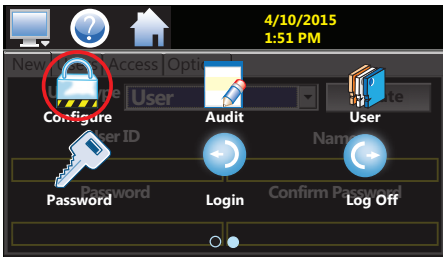

Fig. 19: Press Configure Icon

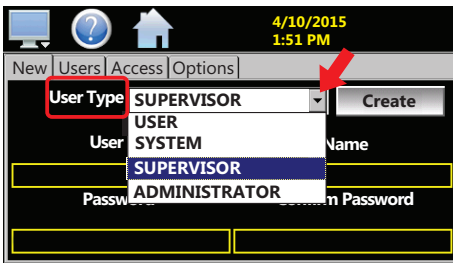

Fig. 20: Select Supervisor

7. Press the HOME icon to return to the Home screen. Press MONITOR icon, then press CONFIGURE icon (Fig. 19).

8. Select Supervisor from the User Type drop-down list (Fig. 20).

9. Press the USER ID, NAME, and PASSWORD boxes to bring up the keyboard for each category and enter the relevant information. After entering each category, hit DONE in the lower right-hand corner on the keyboard. When finished, press CREATE (Fig. 21).

10. New User Created screen appears. Press OK (Fig. 22). NOTE: After setting up the personal supervisor account, use this as a personal login from this point on.

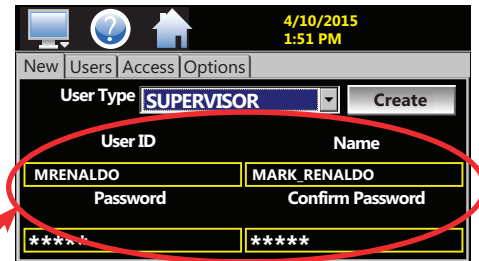

Fig. 21: Set up New Supervisor Account



Fig. 22: New User Created Confirmation

Create User Account: Set up non-supervisory user accounts, which uses the same procedure as for a supervisor account.

User Security Levels – You can enter up to 30 users, each with unique ID, full name and password. There are four user levels—Administrator, Supervisor, Systems and User.

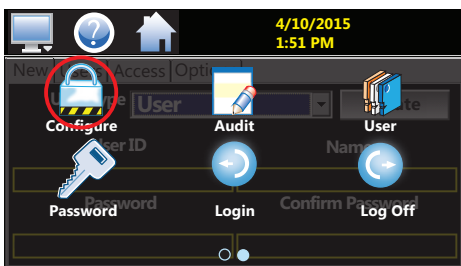

Fig. 23: Press Configure Icon

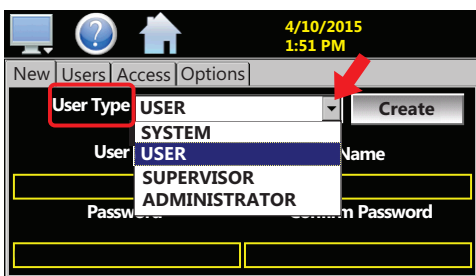

Fig. 24: Select User from Drop Down List

11. Press HOME-MONITOR Icons, then swipe screen to arrive at the CONFIGURE icon and press CONFIGURE (Fig. 23).

12. Select USER from USER TYPE drop-down menu (Fig. 24).

13. Press the USER ID, NAME, and PASSWORD boxes to bring up the keyboard for each category and enter the relevant information. After entering each category, hit DONE in the lower right-hand corner on the keyboard. When finished, press CREATE (Fig. 25).

14. When a new USER is created, a pop-up confirmation will appear that says “New User Created.” Press OK (Fig. 26).

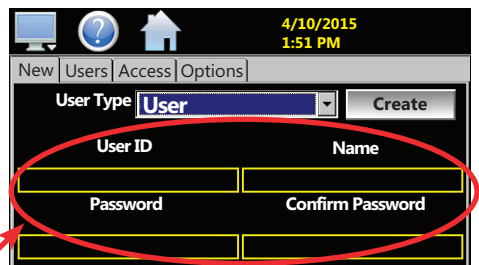

Fig. 25: Enter User ID and Password Info

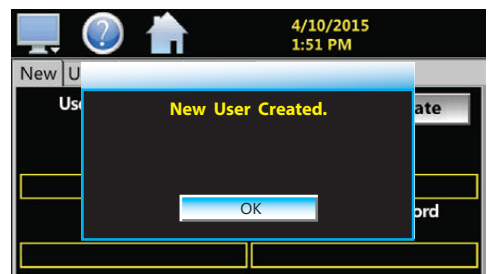

Fig. 26: New User Created Confirmation

User Log In/Log Off

- To log in, select HOME - MONITOR (swipe screen left to right) - LOGIN icons (Fig. 27).



Fig. 27: Login Icon

- Use the pop-up Keyboard to log in (Fig. 28). Tap on the User field to enter the user name. Tap on the Pwd field to enter the user password.



Fig. 28: Keyboard

- To log off, select HOME - MONITOR (swipe screen left to right) - LOG OFF icon (Fig. 27). A pop-up will ask if you want to log off. Select YES to log off, or NO to abort the log off.

Note: The user may be limited in what applications they have access rights to as defined by the system administrator.

Note: Specific Administrator Only tasks are flagged (Admin Only Task) throughout the programming section of this manual.

Navigation

The Touch Screen provides both text based PC style menus (Fig. 31) and icon based/slide page navigation menus. The user can select either type at any time from the Navigation screen.

- Select HOME - MONITOR - SETTINGS - NAVIGATION icons (Fig. 29).

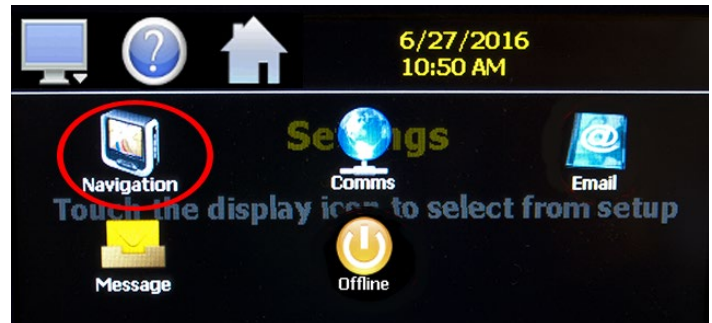

Fig. 29: Navigation Icon

- Select the button for the desired menu type (Fig. 30). When one selection is made, the other will be de-selected. The button indicator for the active selection illuminates to show the current selection.

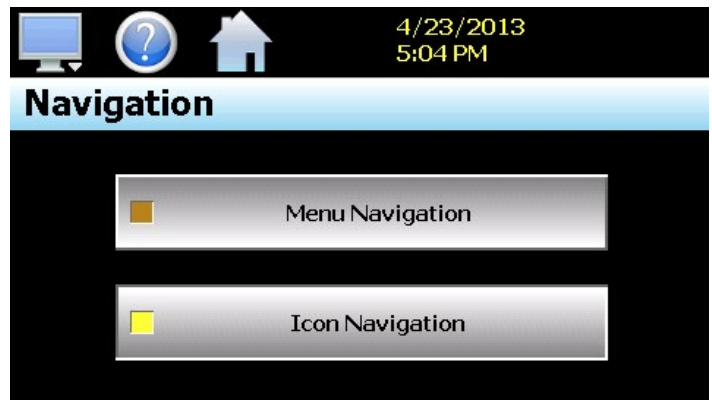

Fig. 30: Navigation Screen



Fig. 31: Navigation PC style Menu

Advanced Touch Screen Programming

User Accounts (Admin Task)

An Administrator will have access to view all user accounts, but will not have the ability to view their passwords. An Administrator can delete a user account and also change the user password.

Change User Password

1. To change a user password, select the HOME - MONITOR - (swipe screen left to right) - CONFIGURE icons (Fig. 32). When the keyboard pops up (Fig. 35), log in.

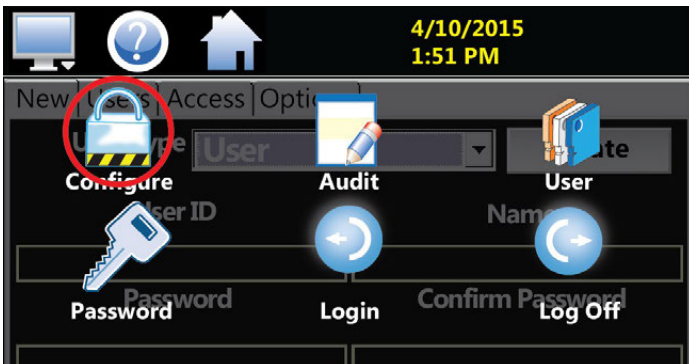

Fig. 32: Configure Icon

2. At the CONFIGURE screen (Fig. 33), select the USERS tab to view information on every user entered into the system. Use the blue up and down arrows in the upper right-hand corner to scroll through the list.
3. Select a user from the list (it becomes highlighted) and press PASSWORD on the bottom of the screen.

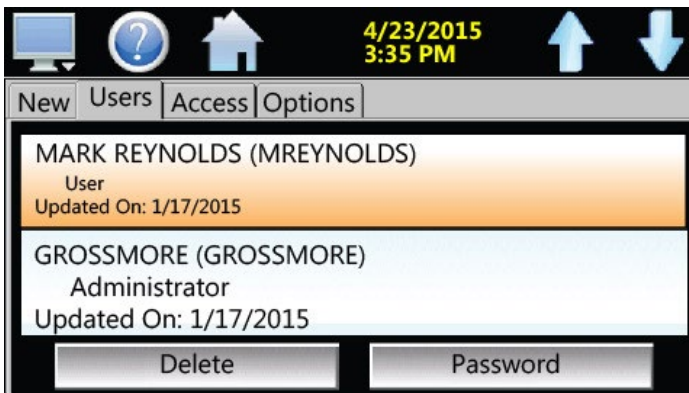

Fig. 33: View Users Screen

4. At the Password screen (Fig. 34), tap inside the yellow box "New Password."

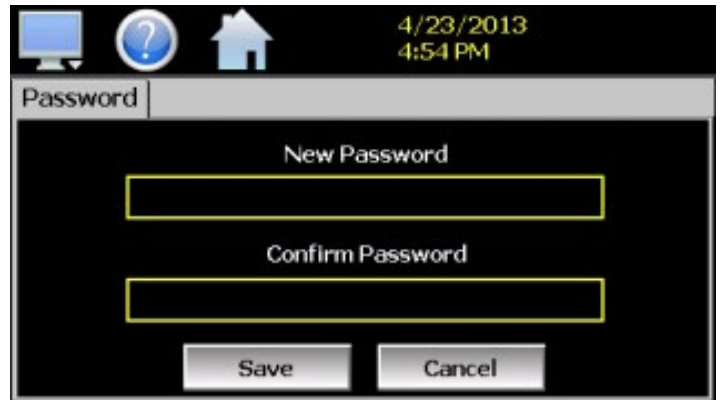

Fig. 34: Password Screen - Change User Password

5. Use the pop-up Keyboard to enter a new password in the yellow box. Re-enter the new password in the "Confirm Password" yellow box. Select the DONE button in the lower right corner of the Keyboard when finished.



Fig. 35: Keyboard

6. When done, press the SAVE button on the PASSWORD screen.
7. To delete a user, select the user from the list and press the DELETE button on the bottom of the USERS screen.

Setting User Access (Admin Task)

The ACCESS tab on the CONFIGURE screen allows an administrator to assign user permissions.

1. Select the desired permission from the list. Press the ON/OFF buttons at the bottom of the screen to enable or disable the permission for a user level. (See "Appendix A – System Security User Access List" for available user access rights.)

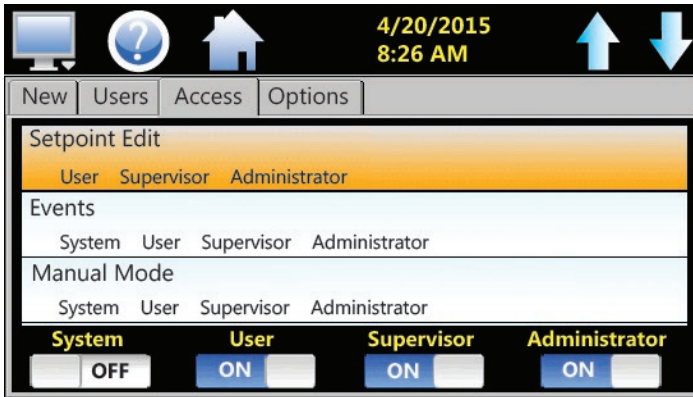

Fig. 36: Set User Access

Set Password Aging (Admin Task)

The OPTIONS tab on the CONFIGURE screen (Fig. 36) is for setting Password Aging Days. This is a global field for all users. The aging value starts the day the user is entered into the system. Set the values and options below as needed (Fig. 37).

Password Aging Days	The numeric value can be between 0 and 365 days. Entering 0 into the field disables password aging.
Verification	When enabled, Verification requires a second log in before the process value can be changed.
Audit	A global setting that turns the audit trail on or off.
Security	A global setting that turns the security on or off. The Security setting must be enabled in order to enable the audit trail.

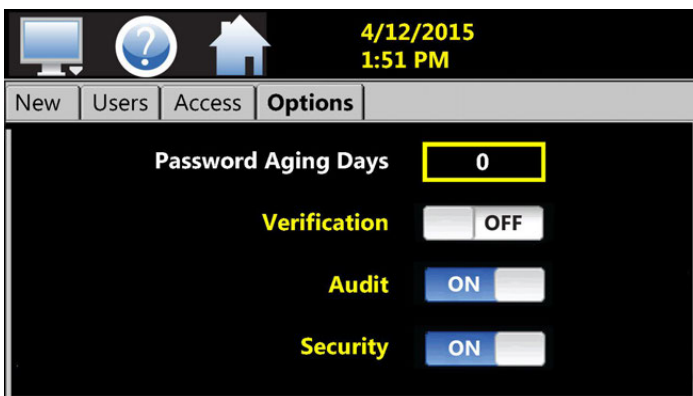

Fig. 37: Set Password Aging Security Option

Audit Trail

The AUDIT function displays all user actions affecting the system for any given day. The Touch Screen controller can store daily audit files for a period of a year or longer (time based on storage usage for data history). Each time a user takes an action that affects the operation of the system (changing a set point, start/stop data logging, changes an alarm set point, etc.), the action is written to a file. NOTE: If no actions occurred on a given day, an audit file will not be created for that day.

1. To access Audit files, select HOME - MONITOR - (swipe screen) AUDIT icons (Fig. 38).

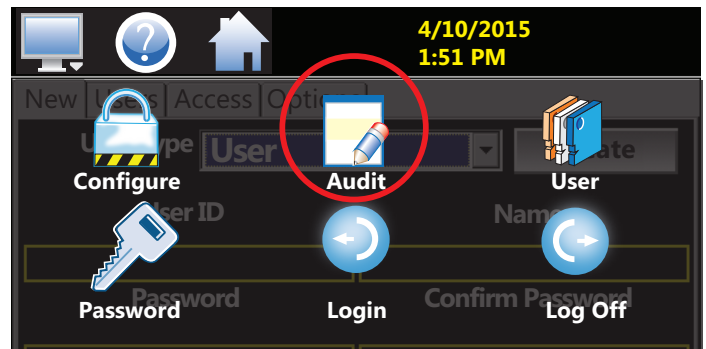

Fig. 38: Audit Icon

2. At the Audit File screen (Fig. 39), press the OPEN button, select a file (Audit file names are listed as month_day_year), press Open.

Actions recorded to the file includes the date/time occurrence and the user (if logged in) who made the change. If no user is logged in, the default user is "Device Manager."

The E-mail icon allows the user to send a copy of the currently opened audit trail file to any user configured in the controller.

3. Press the E-mail icon. An "Add Recipients" window will display. Select recipients for the file from the e-mail addresses configured under the controller e-mail settings.

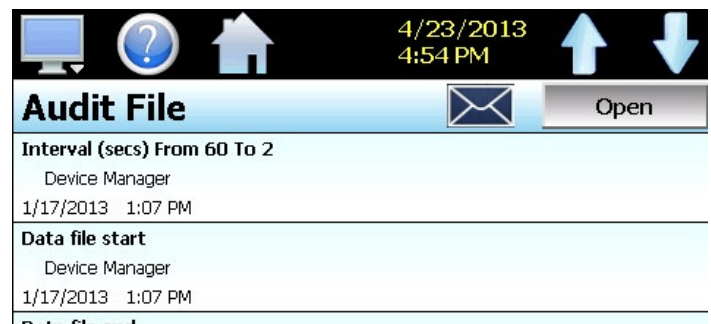

Fig. 39: Audit Screen

Notifications

Current settings, operational conditions and the current logged in user can be quickly viewed.

1. Press the yellow time/date at the top of the screen. A drop-down list (Fig. 40) appears listing the current status of various functions. Swipe the list to view the whole list. Press the yellow time/date again to close the list.

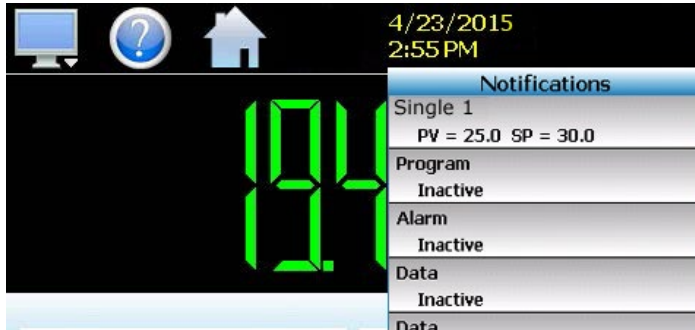

Fig. 40: Notification List

Maximum/Minimum Limits Temperature Set Points

Temperature settings may be changed at any time. The alarm will activate if the set point is changed more than 10 degrees below the actual temperature. See the Maximum/Minimum Limits Temperature Set Points table below for various warming cabinets.

Note: If the alarm is activated under normal operating conditions, turn off power to specific chamber and call your MAC Medical representative at 1-877-828-9975.

Caution **Burn Hazard:** DO NOT raise the set point temperature to increase the rate of heating. This could overheat the contents leading to possible patient burns.

Warning **Explosion Hazard:** DO NOT exceed 150°F for non-vented closures (screw caps, crimp seals, plastic pouches, etc. DO NOT exceed pre-sterile solution manufacturer's temperature requirements.

Maximum/Minimum Limits Temperature Set Points and Temperature Tolerances on Warming Cabinet Units			
Warmer Cabinet Model	Max Temp Set Point	Min Temp Set Point	Temperature Tolerance
Single chamber units SWC182424-TS, SWC182436-TS, SWC183024-TS, SWC182464-TS, SWC242436-TS, SWC243024-TS, SWC242424-TS	160°F (71°C)	90°F (32°C)	±1°F
Single chamber unit SWC183036-TS, SWC243036-TS			±2°F
Single chamber unit SWC182474-TS, SWC183064-TS, SWC183074-TS, SWC242464-TS, SWC242474-TS, SWC243064-TS, SWC243074-TS			±3°F
Dual Chamber units (Upper Chamber) DWC182464T-TS, DWC183064T-TS, DWC182474T-TS, DWC183074T-TS, DWC242474T-TS, DWC243074T-TS			±1°F
Dual Chamber Units (Upper Chamber) DWC182474E-TS, DWC183064T, DWC183074E-TS, DWC242474E-TS, DWC243064T-TS, DWC243074E-TS, DWC242464T-TS			±2°F
Dual Chamber units (Lower Chamber) DWC182464T-TS, DWC182474E-TS, DWC183064T-TS, DWC182474T-TS, DWC183074T-TS, DWC183074E-TS, DWC242464T-TS, DWC242474E-TS, DWC243064T-TS, DWC243074E-TS			±2°F
Dual Chamber units (Lower Chamber) DWC242474T-TS, DWC243074T-TS			±3°F

Single and Dual Chamber Temperature Setting

The HOME screen shows the current temperature (in Fahrenheit or Celsius), its data loop (in green), its set point (in red), and percentage of output (in white) to attain or maintain the temperature.

For single chamber units, the temperature loop name is called "Single" (Fig. 41).

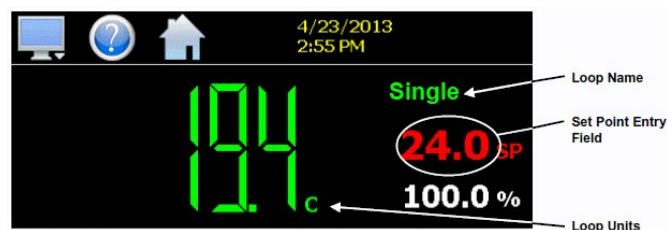

Fig. 41: Single Chamber Temperature and Setpoint Screen

For dual units, "UPPER" and "LOWER" identify the temperature loop settings for upper and lower chambers (Fig. 42).



Fig. 42: Dual Chamber Temperatures and Set Points

1. To change the chamber set point temperature, from the HOME screen press on the red set point letters of the temperature loop (Fig. 43).

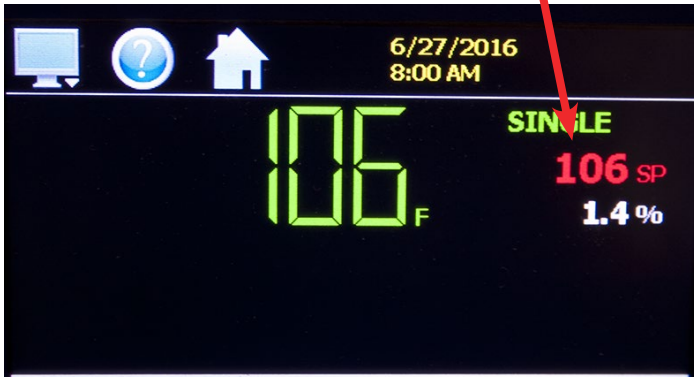

Fig. 43: Single Chamber set at 106 degrees

2. A keypad appears (Fig. 44). The Minimum/Maximum limits for temperature settings are shown on the left center.

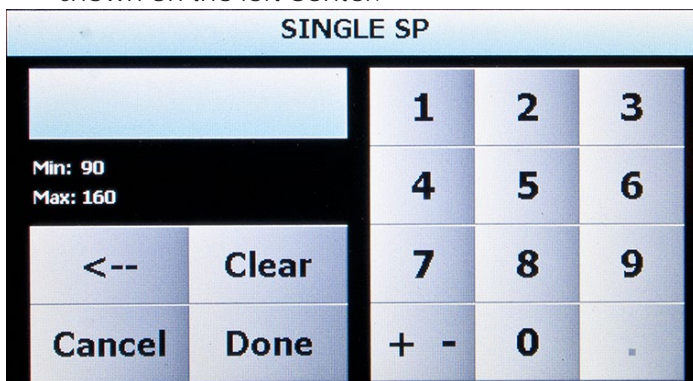

Fig. 44: Set Point Change Screen

3. Using the keypad, input the new set point and press DONE when finished (Fig. 45).



Fig. 45: Input New Settings

4. The new set point shows on the HOME screen (Fig. 46).

5. Note the percent of output reading has changed (Fig. 46). This number will decrease as the chamber adjusts its temperature to its new set point temperature.

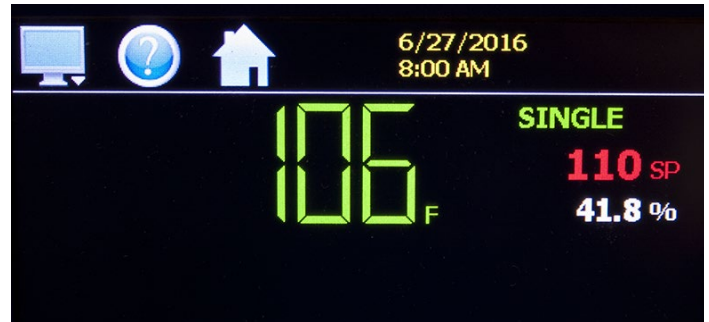

Fig. 46: Set Point Changes to 110 degrees

6. After a period of time, the HOME screen shows that the chamber temperature has reached its new temperature set point (Fig. 47).

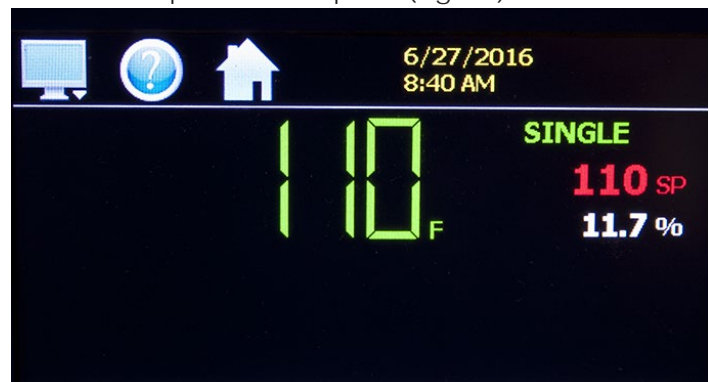

Fig. 47: Chamber Temperature at New Setting

Switching Temperature Units (Admin Task)

1. This setting is performed only by the Supervisor or Administrator. If Data Logging is turned on, it must be turned off in order to switch Fahrenheit/Celsius temperature units.
2. Select HOME - MONITOR - (swipe screen) SETTINGS icon (Fig. 48).

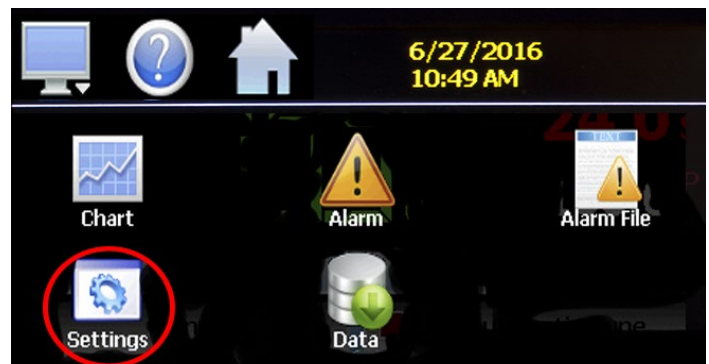

Fig. 48: Settings Icon

- At the next screen, select MONITOR (display) icon (Fig. 49).

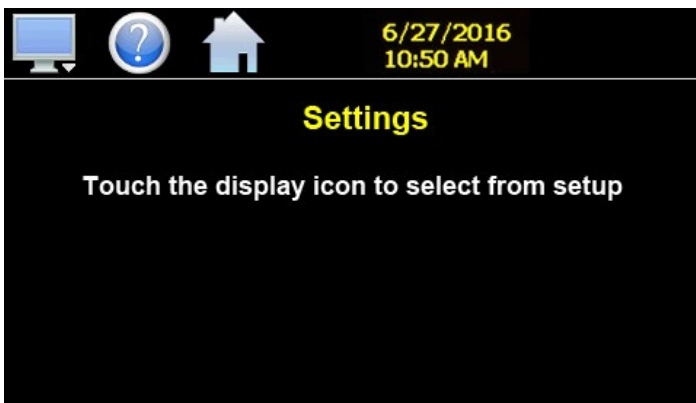

Fig. 49: Select Monitor (Display) Icon

- Select OFFLINE icon (Fig. 50).

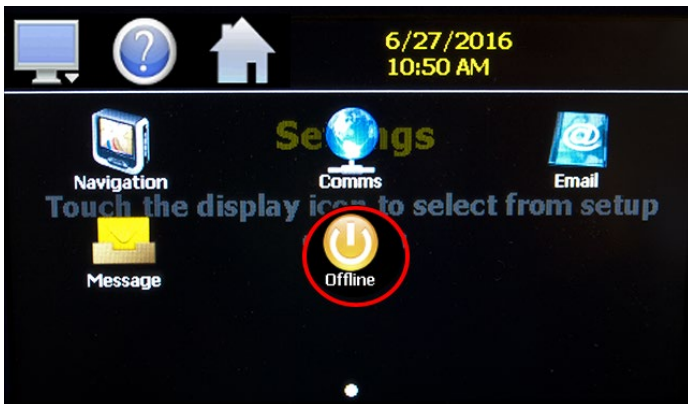

Fig. 50: OFFLINE Icon

- Select YES to enter OFFLINE mode (Fig. 51).
- At the next screen "OFFLINE Touch the display icon from setup" (Fig. 49) select the MONITOR (display) icon.

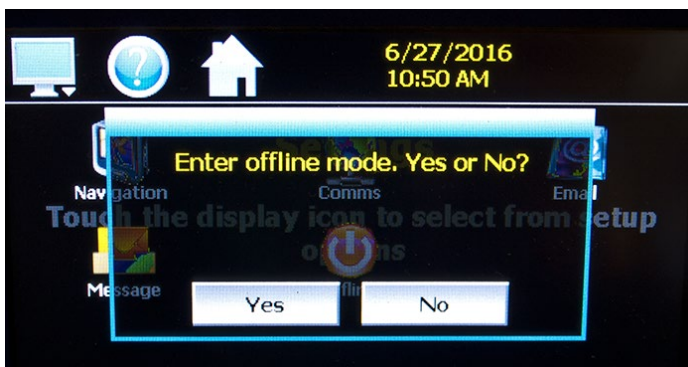

Fig. 51: Enter Offline Yes/No

- Select UNITS icon (Fig. 52).

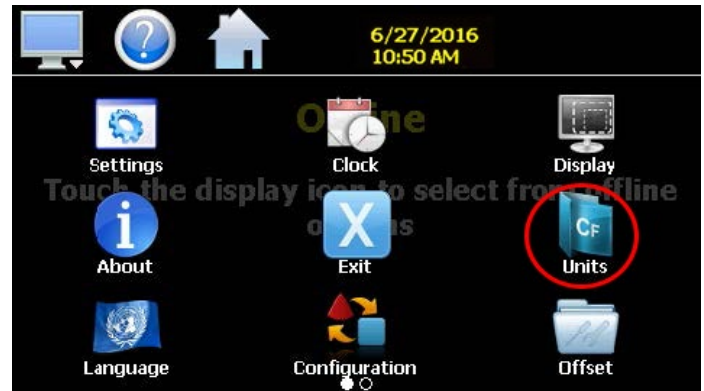

Fig. 52: Select Units Icon

- The temperature unit with a yellow box in its button is the currently active unit. To change the unit, select the desired unit (Fig. 53)

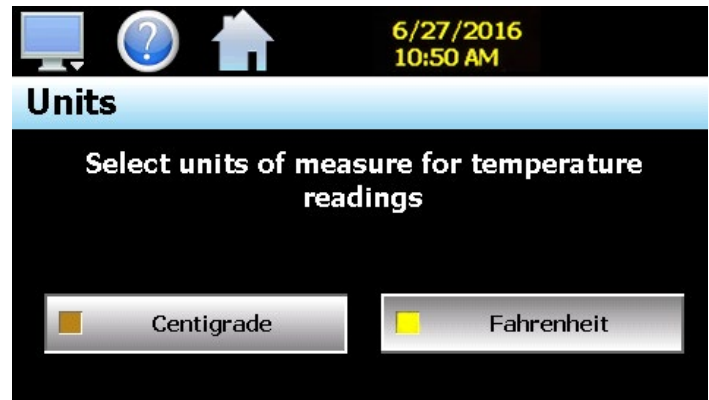

Fig. 53: Select Temperature Unit

- After selecting the desired temperature unit, select YES to accept (Fig. 54).

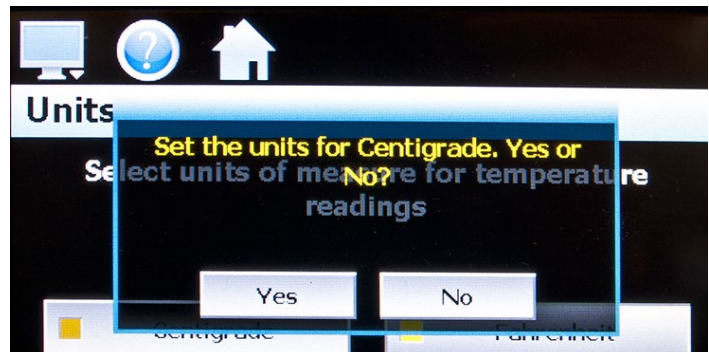

Fig. 54: Set Unit Yes/No

- The Touch screen controller will automatically calculate to convert to either Fahrenheit or Celsius. The HOME screen will thereafter show the chamber temperature in the converted temperature unit.

Data File Naming

1. Select HOME - MONITOR (swipe screen left to right) - DATA icons (Fig. 55).

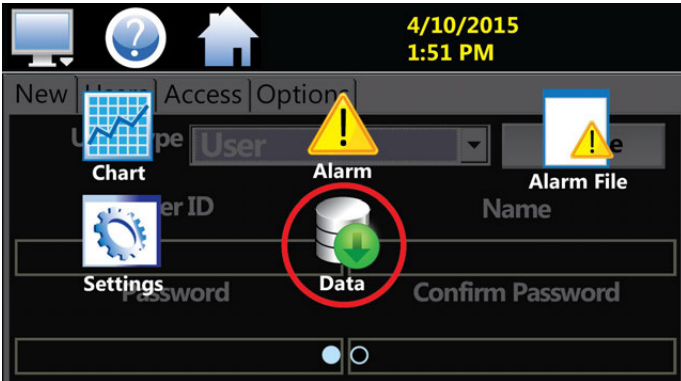

Fig. 55: Data Icon

2. At the DATA screen (Fig. 56), the green box inside the "DATA" button is dark green (OFF). The OFF position allows you to make entries on the DATA screen.

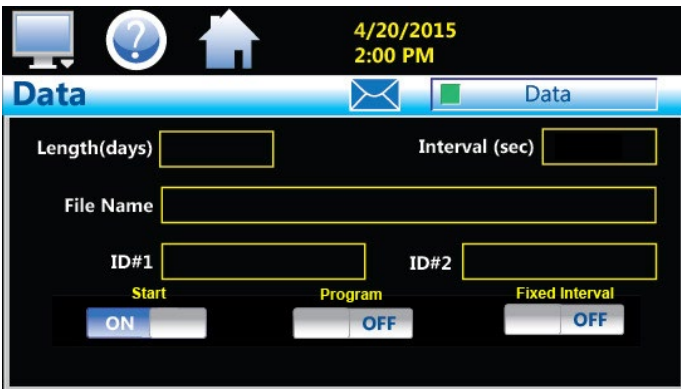

Fig. 56: Data Screen

3. Tap the box named FILE NAME. A pop-up keyboard will appear (Fig. 57).
4. Using the keyboard, enter the FILE NAME in the appropriate box on the DATA Screen. File name length can be up to 16 characters long. Your file will save as Filename_mm_dd_yyyy_hh_mm_ss
5. Tap on DONE when finished.

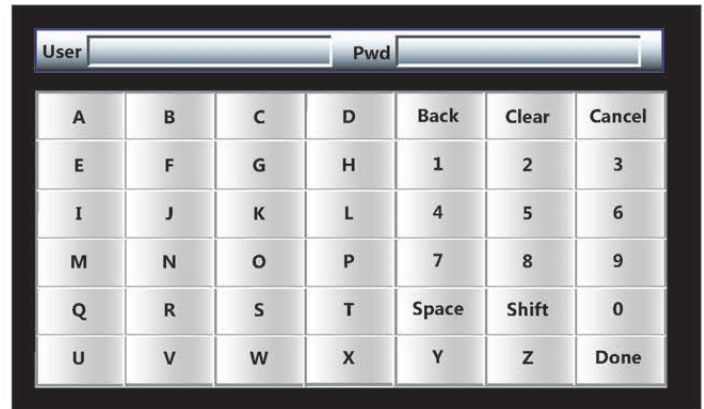

Fig. 57: Keyboard

Data Logging

The Touch Screen controller logs data to its SD card. Current data for each variable is written to the log at a fixed interval based on the settings entered in the Length and Interval fields. The table below lists and describes the Data screen variables.

LENGTH OF DAYS	Sets a data file length in number of days (from 1 to 31 days). Once the selected number of days has elapsed, a new data file will be created and logging will continue in the new file.
INTERVAL (Sec)	The number of seconds for the data to be logged. The Interval can be manually set from 2 to 1860 seconds. To do this, toggle OFF "Fixed Interval" and enter the desired logging rate in seconds.
FIXED INTERVAL	When toggled ON, the logging interval will be automatically set to record at minute intervals based on the number of days set for the file. If the file is set for 1 day in length, the logging rate will be at 1 minute intervals. If the file is set for 7 days, then the logging rate will be every 7 minutes. The "Fixed Interval" keeps the file size manageable.
ID#1 and ID#2	Allows more specific identification of the file.
START	Automatically turns on data logging.
PROGRAM	Should be kept OFF.

1. After creating a file name in the DATA screen, touch the LENGTH (days) box. Enter the number of days (1 to 31) the data will be logged on the pop-up Interval Keypad (Fig. 57).



Fig. 58: Interval Keypad - Set Length - Days

2. Select the INTERVAL Box (Fig. 56). A pop-up keypad appears.
3. Use the Keypad to change the value in the INTERVAL box (Fig. 59).

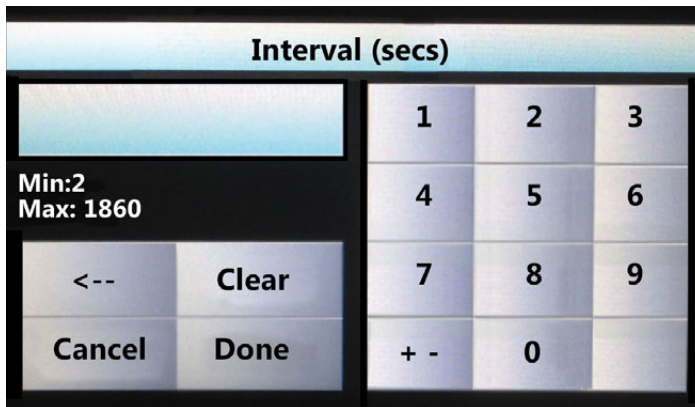

Fig. 59: Interval Keypad - Set Seconds

4. **When finished, toggle on the DATA button to start data logging.** Its dark green box will turn light green, locking the entry boxes until it is toggled off. Data logging can also be started by toggling ON the "Start" option from this screen (Fig. 60).

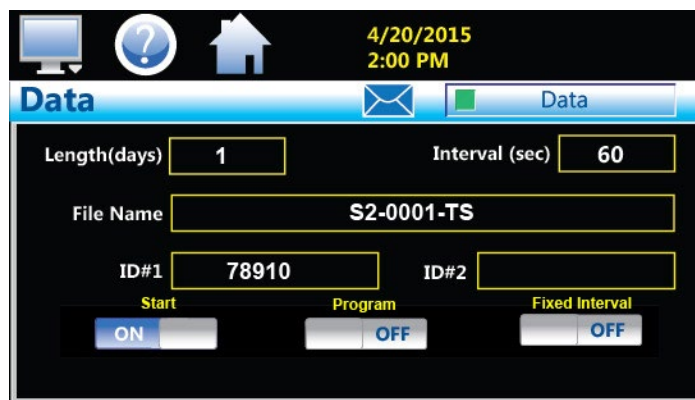

Fig. 60: Completed Data Screen Entries

Selecting Points for Logging

In order for the DATA LOGGING function to operate, variables must be selected and logged to the DATA file. Choose which points are to be logged by selecting ASSIGN from the DATA MENU.

1. Press HOME - MONITOR - (swipe screen) DATA - ASSIGN icons (Fig. 61).

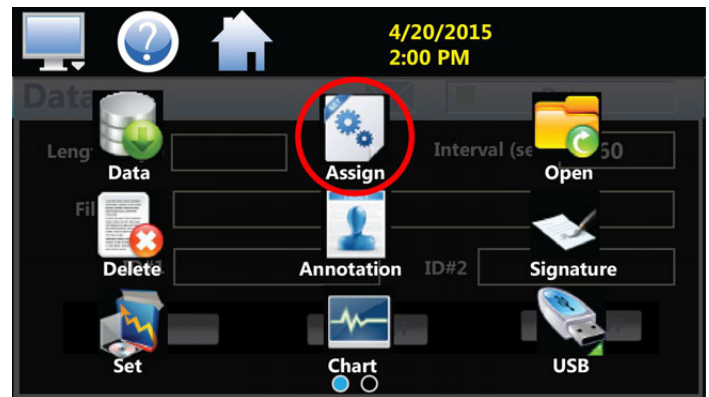

Fig. 61: Assign Icon

Note: A data logging control loop will consist of:

- PV (process variable)
 - SP (set point)
 - %Out (percentage of output) points
2. At the ASSIGN Screen (Figs. 62 & 63), select the desired control loops (single PV, SP or %Out for single chamber program or upper/lower temp PV, SP or %Out for dual chamber program).
 3. Select ON or OFF on the control loop bar(s). (Turning ON enables points to be written to the data file when data logging is on.)

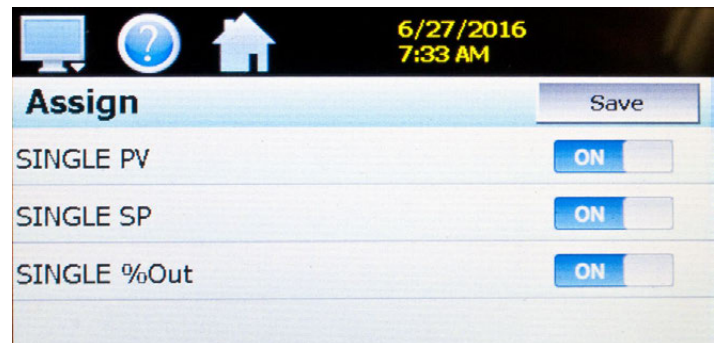

Fig. 62: Assign Screen (Single) - Select Variable

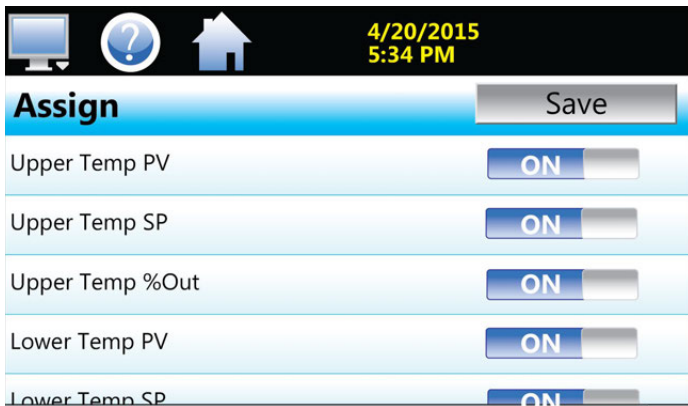

Fig. 63: Assign Screen (Dual) - Select Variable

4. Press the SAVE button to save selections.
5. As soon as the files are saved, the DATA FILES SAVED screen pops up (Fig. 64).

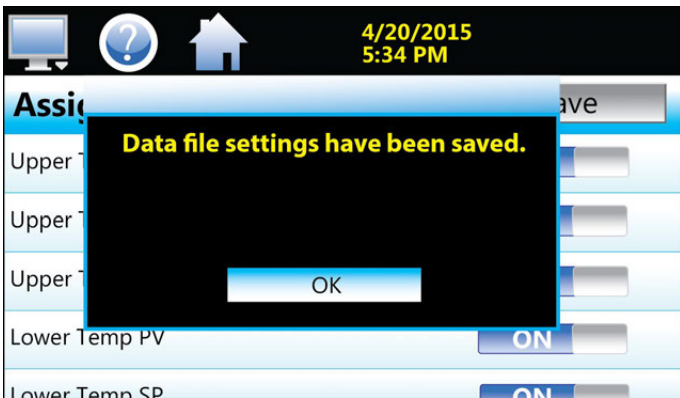

Fig. 64: DATA Files Saved

Charts and Chart Setup

Real-time charts (Fig. 66) can be configured to display the process variable (PV), set point (SP) and percentage of output (%) of each control loop over a selectable period of time. The vertical axis determines the range of displayed data while the horizontal axis determines the history period. The maximum time period that can be shown in a chart is 24 hours.

The rate at which the chart plots a new point is based on the time period to be shown. Each buffer can hold a total of 720 readings for each of the selected channels to plot. The update rate can be calculated by the formula: $\text{time period (in minutes)} \times 60 / 720$. Note that for time periods less than 72 minutes, the update rate will be held to a minimum of 6 seconds. Thus, the update rate will vary from a minimum of 6 seconds (for time periods of 72 minutes or less) up to a maximum of 120 seconds for 1440 minutes (24 hours).

1. The Chart screen is accessed by touching HOME - MONITOR - CHART icons (Fig. 65).

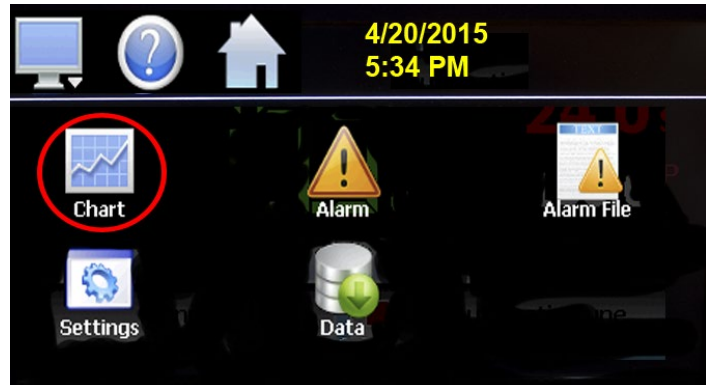

Fig. 65: CHART Icon

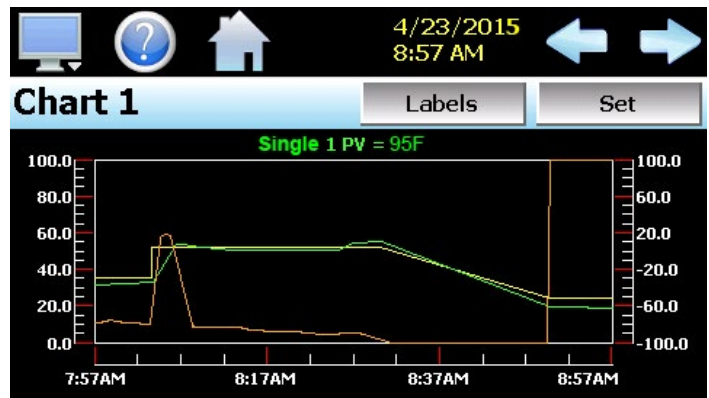

Fig. 66: Chart Sample in Real Time

Labels – Allows cycling through each of the configured plot channels to determine what each colored plot represents as well as view the current value without having to return to the Single or Dual view screens. The left and right scroll arrows allows cycling through each of the four available charts.

Zoom – The charts allows “zoom in” on a particular area for a detailed look at current data. Use your finger to select and zoom in on an area on the chart. To select a portion of the plot, touch and hold the screen with your finger. Drag your finger across the graph to draw a box around the selected area. Removing your finger from the screen causes the chart to redraw with only the selected plot area. Touch the 'X' or 'Y' axis and select Zoom Out to return to the previous zoom setting. Zoom Normal returns to the full display.

Note: A zoomed-in chart will not update with new information. The chart must be in normal view mode in order to update at each time interval. The chart will return to normal automatically when selecting a different screen to view.

- To configure a chart, press the "Set" button in the upper right corner of the chart display.
- The setup screen appears (Fig. 67). To assign channels to the chart, touch the ON/OFF button for the desired items in the list to select them. Select the left or right vertical axis for each item by selecting the item in the list and press the button for the desired "Left" or "Right" axis. The left axis is the default axis selection. If none of the channels are assigned to the right axis, the axis will not be shown on the chart.

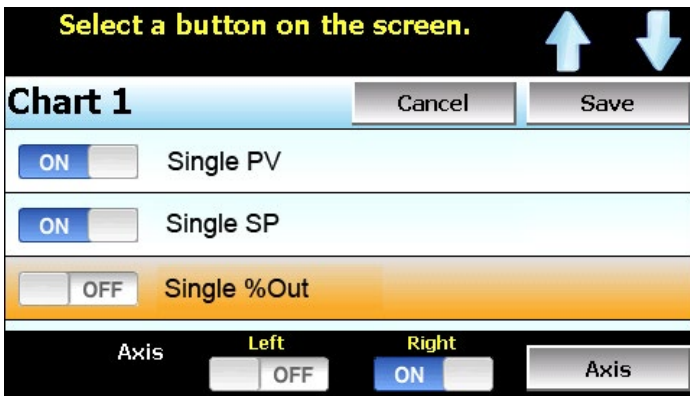

Fig. 67: Chart Set Up Screen

- Once the channel and axis selections have been made, press the "Axis" button to adjust the time period and vertical axis ranges of the graph (Fig. 68).

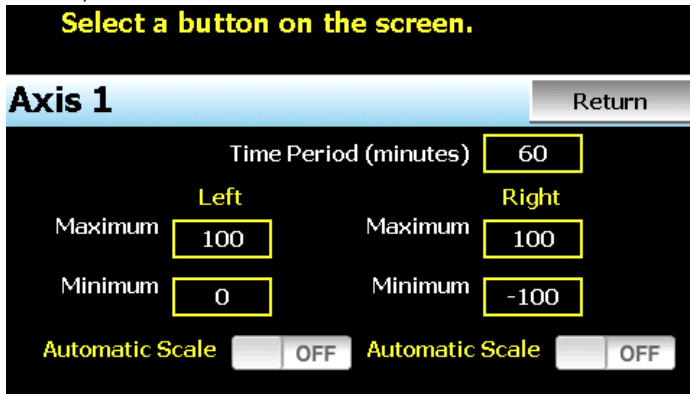

Fig. 68: Set Axis Time Period

Time Period	Adjusts the displayed time period for the graph. Allowable range is 4 to 1440 minutes (24 hours).
Maximum	The maximum value sets the maximum range of the vertical axis with a minimum value of -32,760 and a maximum of 32,760.
Minimum	The minimum value sets the minimum range of the vertical axis with a minimum value of -32,760 and a maximum of 32,760.
Automatic Scale	When on, the vertical axis automatically adjust its zero and span as needed to display the selected plot channels.

History Plot Setup

This allows the user to select any time frame (zoom in/out) from the historical data file as well as select up to six channels of data to plot.

- To edit the settings for the historical plot, select HOME - MONITOR - CHART - SET icons (Fig. 69).



Fig. 69: Set Icon

- At the Chart Settings screen (Fig. 70), any point from the data file can be selected along with the vertical axis to be used for each channel to be plotted. Select channels from the list by turning them on or off. Use the "Left" and "Right" axis buttons to assign the selected item to the left or right axis for the plot range.



Fig. 70: Chart Settings

- To adjust the period of time to plot from the data file, press the "Time" button. The File(start/end) screen will appear (Fig. 71).

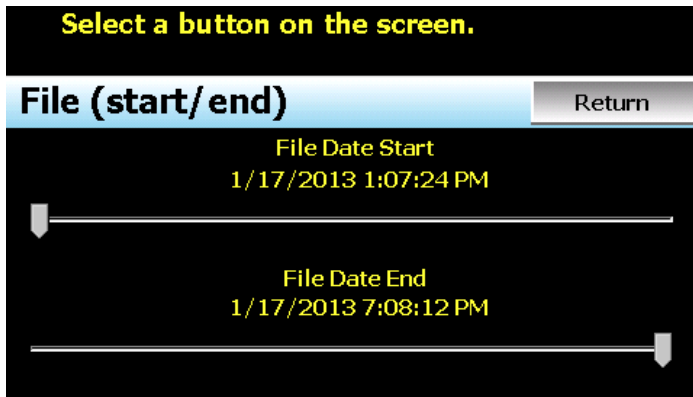

Fig. 71: Set File (start/end) Time Scale

- The start and end dates for the currently loaded file will show time in hours, minutes and seconds. The "File Date Start" and "File Date End" sliders are used to select a time span for historical viewing. Once the desired start and end times have been set, press the "Return" button to return to the Chart Settings screen.

Accessing Historical Data

- Select HOME - MONITOR - DATA Icons.
- After the DATA Screen opens, select MONITOR icon.
- Select OPEN Icon (Fig. 72) on the DATA screen. Touching the OPEN Icon brings up a screen showing the available files.

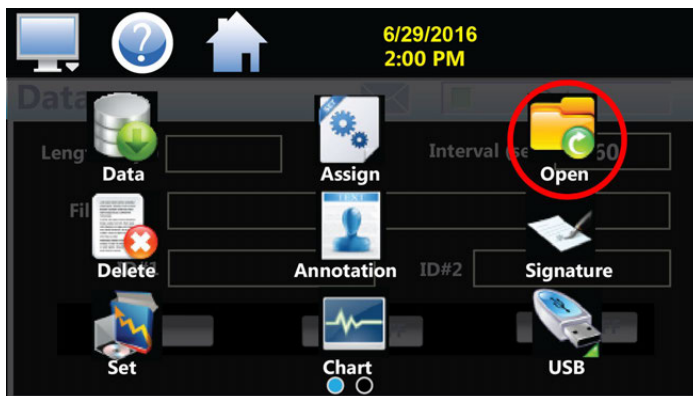

Fig. 72: OPEN Icon

- Touch the file to be opened. The bar containing the title will become highlighted in orange (Fig. 73).

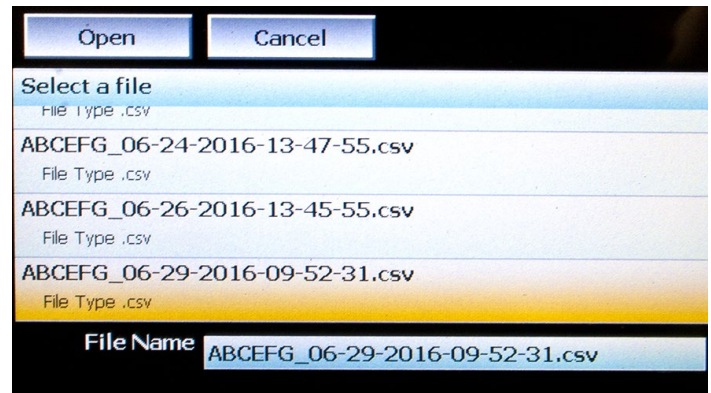

Fig. 73: File OPEN Screen

- Touch the OPEN Button to display the file.
- Upon selecting a file, a pop-up will ask whether to trend that file (Fig. 74). Select YES.

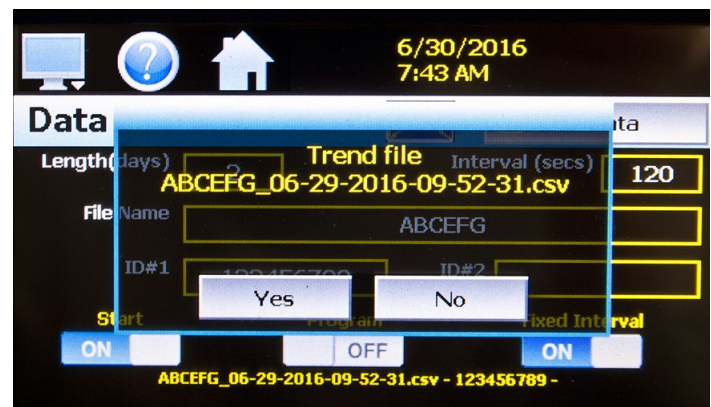

Fig. 74: Trend File

The history chart (Fig. 75) plots the data from the currently opened history file according to the selections made under chart setup. If a file has not been opened or data points have not been assigned to a plot, the display controller will alert the user to correct the problem. The 'X' and 'Y' axis scales are set to auto scale based on current values for each plot channel so no user action is required.

The historical graph provides the same zoom feature as the real-time charts so the user can zoom in on a particular area of the historical plot by dragging their finger across the screen to draw a rectangle around the desired plot area.

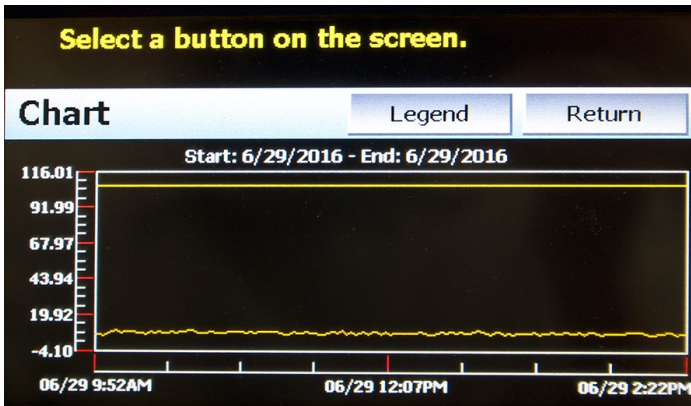

Fig. 75: Historical Chart - Legend Button

- Press LEGEND to access information on the names of the selected plot channels, which axis they are associated with, and the color used to display the plot channel (Fig. 76). Pressing the button again will toggle the display back to the historical chart.

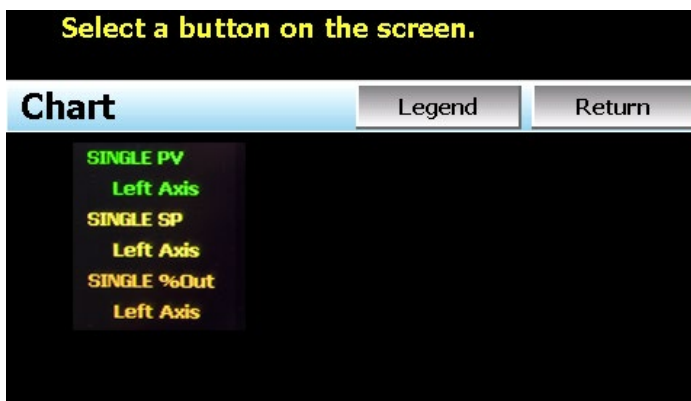

Fig. 76: Plot Channel - Axis Display

NOTE: When toggling with the Legend button between the historical chart and the legend screen, it may take several seconds for the chart to become visible depending on the size of the data file and number of channels selected to plot.

- When finished viewing the historical chart, press RETURN to exit the historical data viewer and return to the main data log screen.

USB File Transfer

Data and setup storage files (programs, alarm log and audit trail files) periodically need maintenance. In time, storage devices fill up and files require backup or file deletion when no longer needed.

NOTE: The data log files, programs, alarm log and audit trail directories are saved to the internal SD card (not the USB memory stick device) plugged into the controller interface. Never unplug the SD card

when the controller is powered up or loss of data may result.

The USB file transfer screen allows the user to copy or erase files from the internal SD card. Complete file directories for all file types can be copied to the USB memory stick and erased from the internal SD card. The current status for file functions is displayed for the operator during copy/delete operations.

NOTE: All file transfer functions can be used while data logging is running. If the operator needs to back up or delete files from the system, a large number of files could take considerable time to back up and delete from memory. The file transfer screen will be locked during file transfer, so plan the timing appropriately when access to other screen functions is not required. When data logging is running, the current data log file will not be copied or deleted while using the file transfer functions. This protects the current file, ensuring that the data file is complete before being copied and cannot be deleted from memory while it is still in operation.

NOTE: The USB memory stick must be inserted into the USB port for the USB File operation to function. USB memory stick manufacturing variations may cause a few seconds up to 30 seconds to elapse for the controller to recognize the device when it is plugged in. Allow sufficient time for device recognition before attempting any USB file transfer or the controller will indicate a file transfer/memory stick error.

As files are being copied to the USB storage device, a directory for each file type will be created to store the copied files. The directory structure is:

Program files directory: **Programs_mm_dd_yyyy-hh_mm_ss**
 Alarm files directory: **Alarm Files_mm_dd_yyyy-hh_mm_ss**
 Audit files directory: **Audit Files_mm_dd_yyyy-hh_mm_ss**
 Data files directory **Data Files_mm_dd_yyyy-hh_mm_ss**

Using the date and time as part of the directory name assists in tracking the date and time of the file transfer. If a file type is transferred more than once in a day, the files will be grouped logically by time.

The data files saved to the USB memory stick are in ".csv" format, which can be opened directly with Microsoft Excel or any program that opens a comma separated file format. Copy or empty the "Data Files" directory by plugging the USB device into a PC's USB port. The device then becomes like any removable disk attached to the computer and can be manipulated once plugged into the PC.

IMPORTANT: Once files are deleted from the controller, they are gone and cannot be retrieved.

USB File Transfer Screens

The USB File Transfer Screen allows the user to copy or delete files from the internal SD card. Complete file directories for all file types can be copied to the USB stick and erased from the internal SD card.

1. Select HOME - MONITOR - (swipe screen) DATA - USB icons (Fig. 77).

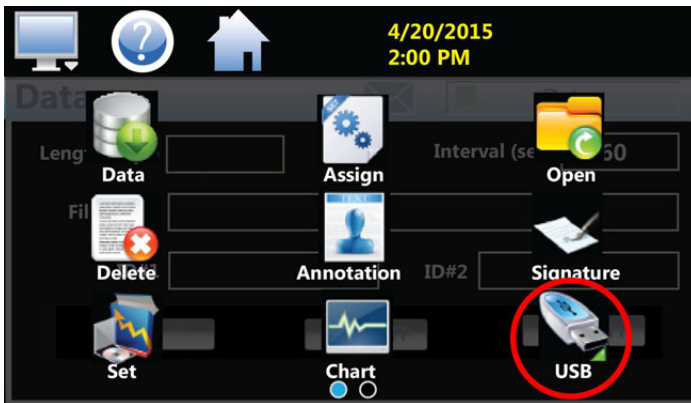

Fig. 77: USB Icon

CAUTION: All data log files, programs, alarm log, and audit trail directories are saved to the internal SD card (not the USB memory stick). NEVER unplug the SD card when the interface is powered up. This can result in loss of data.

2. To copy files, insert the USB stick into the USB port on the front of the warmer cabinet (See Figure 4, page 8).
3. Press the MONITOR Icon.
4. Select the file type by pressing the DOWN arrow next in the EXPORT TYPE window. The drop-down menu selections are PROGRAM, ALARM, AUDIT, and DATA (Fig. 78).

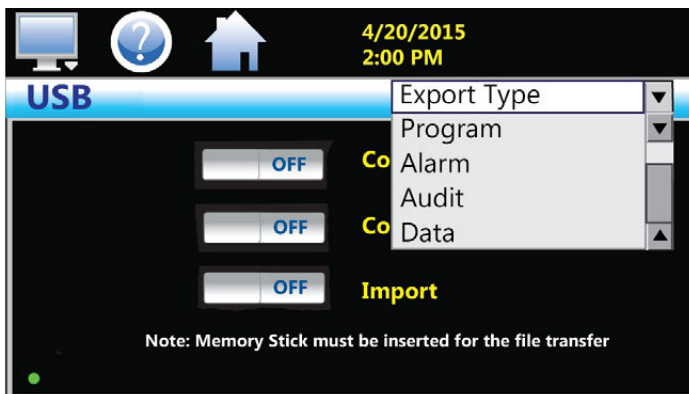

Fig. 78: Select USB Export Type

5. Tap the COPY button. The OFF button is replaced by ON button (Fig. 79). A progress bar will show all related files being copied to the USB stick.
6. Press Export Type next to drop-down arrow on the upper-left of the screen.
7. Select DATA from the drop-down menu.
8. Select COPY. The OFF button is replaced by the ON button

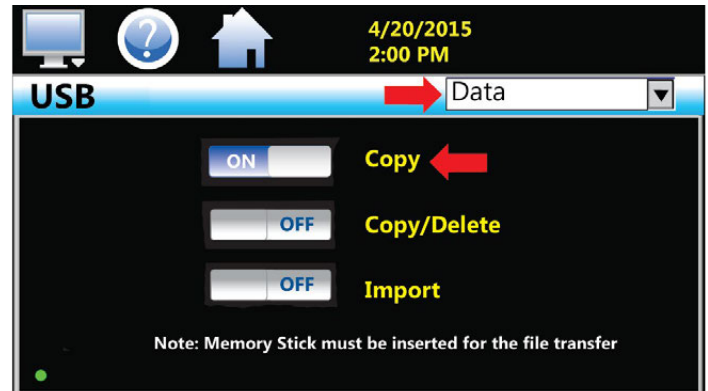

Fig. 79: Select Copy

9. To COPY/DELETE files, insert the USB stick into the USB port on the front of the warmer cabinet.
10. Select the file type to be copied and deleted from the internal memory from the "Export Type" drop down menu. The selections are PROGRAM, ALARM, AUDIT, and DATA.
11. Touch the COPY/DELETE button. The OFF button on the L/H side is replaced by the ON button on the L/H side of the selection.
12. All related files will be copied to the USB stick along with a progress bar and deleted from the internal memory.
13. The COPY and IMPORT buttons work the same way except they do not delete the files from the internal memory.

AORN recommends the cabinet temperature should be routinely monitored and documented on a temperature log or on a record provided by an electronic recording system, according to facility policy.

FTP/WAN Backup

The FTP/WAN screen allows the user to configure automatic back-up of all data files contained in the Touch Screen controller memory to a user designated FTP site. When enabled, the controller will automatically back up all data log files, alarm files and audit trail files at 2:00 AM each day. With the delete files selection, the controller will then automatically delete the files from its internal memory after back up. This will maintain the controller's memory automatically, so that continuous data logging can be performed without filling up the available memory space.

Note: Setting up an FTP site on your network may require authorization and/or assistance from your network administrator. Contact your network administrator for proper settings and authorization from your network server (if required) to allow the controller to connect to the designated FTP site.

1. To access the FTP/WAN, select HOME - MONITOR - DATA - MONITOR - (swipe screen) FTP/WAN icons (Fig. 80).

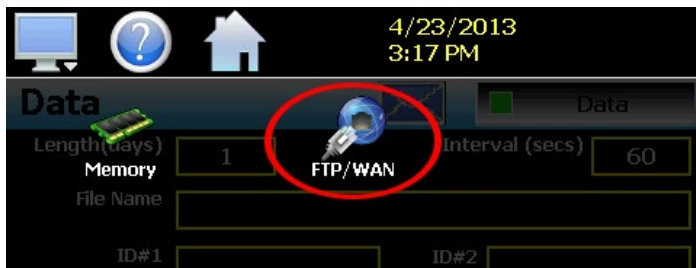

Fig. 80: FTP/WAN icon

2. The FTP/WAN screen appears (Fig. 81). Enter the relevant information (described in the table below) in each box by selecting the box. Use the pop-up keyboard to enter the information.

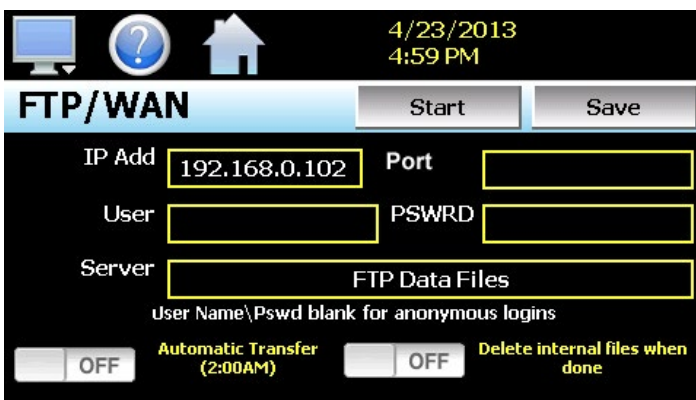

Fig. 81: FTP/WAN Screen

IP ADD	Used to enter the IP address of the FTP site that the Touch Screen controller is to send the files to.
PORT	Used to enter the network port that is to be used by the server to access the FTP site. The default port is 21. The port number can be set from 0 to 65535.
USER	Enter a user name for FTP site access. When the controller connects to the FTP site to transfer files, the user name will be used to identify the connection. If a security login is required, the proper user name will have to be entered in this field. If security is not used, this field can be left blank.
PSWRD (password)	Used in conjunction with the user name field and is for entering a password, if required by your FTP site, so that the Touch Screen can access the site. If security is not used, this field can be left blank.
SERVER	Enters the server directory where the files are to be backed up. When the automatic back-up occurs, the controller will place the historical data files in this directory on the FTP site. The controller will automatically create an 'Alarms' directory and an 'Audit' directory within the specified server directory for backup of the alarm files and audit trail files.
Automatic Transfer (2:00AM)	Turned ON to perform an automatic backup of all historical data files, alarm files and audit trail files contained in its internal memory to the designated FTP site. Note that if data logging is currently active, the active file will not be copied.
Delete internal files when done	Turn ON to delete all data log files, alarm files and audit trail files within its memory after completing the backup to the FTP site. Note that if data logging is currently active, the active file will not be deleted.

3. Once all settings have been made, press the SAVE button to save the settings so that on the next power-up, the entries will be maintained. The START button can be used at any time to perform a manual data backup.

If the files already exist on the FTP site, they will be overwritten on each subsequent backup. If the FTP site is down, or the controller is not connected to the network, a local alarm message on the Alarm screen will indicate a transmission failure.

Note: Typically FTP Server software uses case sensitive alpha-numeric characters for the User name, Password and Server directory. Contact your network administrator for proper settings.

Annotation

The Annotation screen allows the user to add messages to the running data file and view any messages currently associated with a loaded historical data file.

1. To annotate a data file, select HOME - MONITOR - DATA icons. Select a data file and press the DATA button to turn on logging. The Data button will turn light green (Fig. 82).

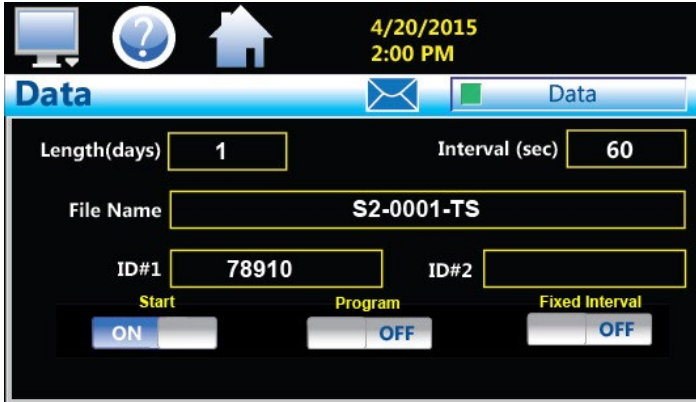

Fig. 82: Running Data File

2. After turning on the data logging for a file, select MONITOR - ANNOTATIONS icons (Fig. 83).



Fig. 83: Annotations icons

When a historical data file is loaded, the Annotation screen will display any messages that were written to the file (Fig. 84). The date, time, user name and description of the data file annotation is shown.

Note that the currently running data log file can be opened as a historical data file, and the current annotations for the running file will be shown.

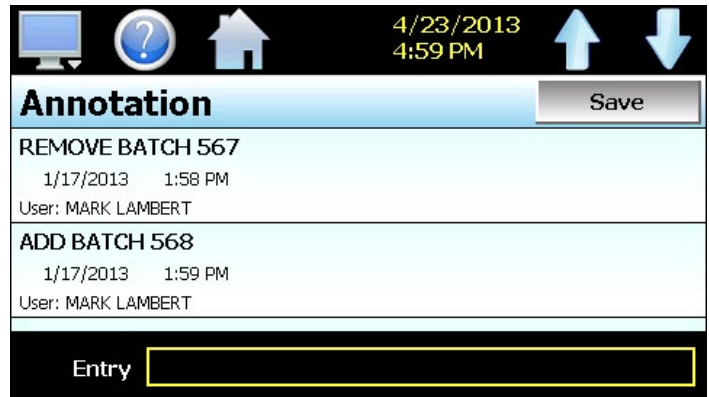

Fig. 84: Annotations List

3. To add an annotation to the running log file, touch the "Entry" field and enter the message on the pop-up keyboard (up to 16 characters maximum).
4. Press the ADD button and the message will be added to the current log file. If the running log file was opened as the historical log file, the annotation will be shown immediately on the screen as it is added. If logging is not currently running, the entry field will be disabled.

Digital Signatures

The Signature screen allows the user to add digital signatures to historical data log files and view any digital signatures currently associated with the loaded historical log file.

1. To view the Digital Signatures screen, select HOME - MONITOR - DATA - MONITOR - OPEN and select an historical file to open.
2. Upon selecting a file, a pop-up will ask whether to trend that file. Select YES. A chart of the trending file will appear. Select RETURN.
3. Select MONITOR - SIGNATURE (Fig. 85).

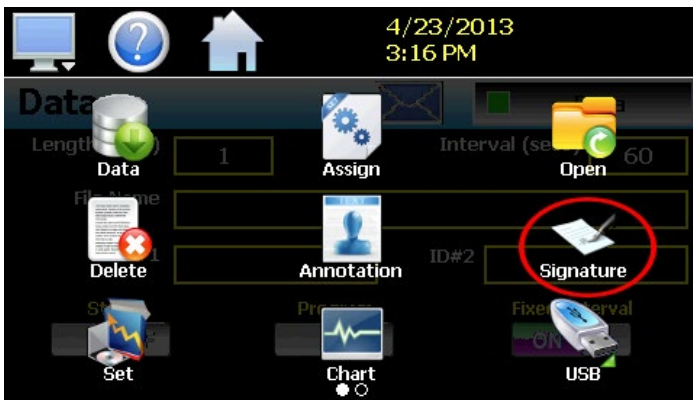

Fig. 85: Signatures Icon

4. The Signature screen (Fig. 86) displays signatures currently associated with this file.
5. To verify a digital signature and ensure that the data file has not been altered, touch the signature in the list box and press the "Verify" button. The Touch Screen controller will compare the signature to the log file to see if any alterations to the data have been made. The controller will then indicate if the signature is valid or not.

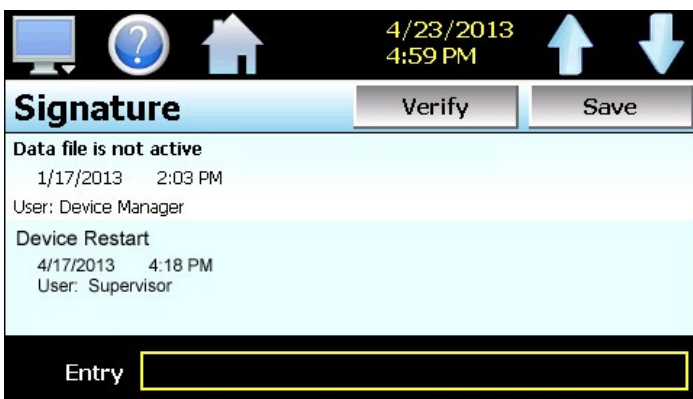

Fig. 86: Signature List

6. If the signature is valid, the historical data file is intact and has not been altered. If the signature is invalid, the data has been altered at some time after the signature was assigned to the file. For data integrity, the controller automatically signs a data file when logging is stopped; however, this only occurs if the "Auto Interval" is selected on the Log screen. If a different logging interval is used, the controller will not automatically sign the file, and it must be signed by a user.
7. To add a digital signature to the historical log file, touch the "Entry" field at the bottom of the Signature screen and enter in the comment line for the signature (up to 16 characters maximum).
8. Press the ADD button and the signature will be added to the log file. The signature includes the date and time of the signature, the user name and comment line. If a user is not logged into the system, the default user name "Device Manager" will be used as the user.
 - A. **Note:** The Signature screen is not available if security is disabled. The Touch Screen controller security module must turned ON in order to digitally sign data log files. (See "Set Password Aging (Admin Task)" on page 21.)

Alarm Function

The Alarm screen is accessed by selecting HOME - MONITOR - ALARM icons (Fig. 87).

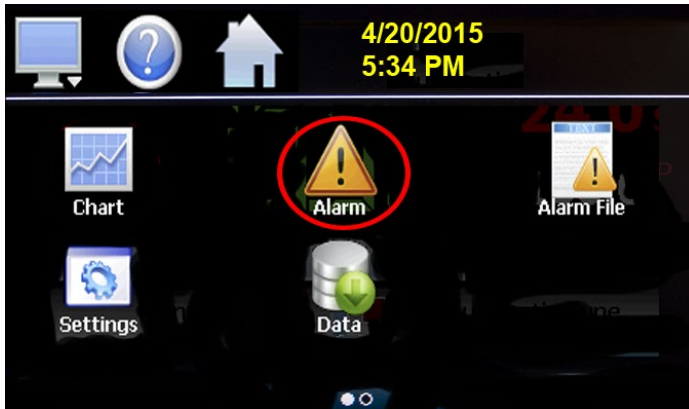

Fig. 87: Alarm Icon

- If an Alarm occurs, the alarm icon will flash on the current screen (Fig. 88). Press the alarm icon to bring up the Alarm screen to view the type of alarm.



Fig. 88: Alarm Appears

- The Alarm screen (Fig. 89) displays a message about the alarm condition with date and time. Select the file to see the Alarm File.



Fig. 89: Select Alarm File

- To silence the audible alarm, press RESET. Once the alarm is reset, the alarm icon will be hidden; however, the alarm condition may still be present.
- The alarm can be removed from the list when cleared by pressing the "Clear" button. Only alarms that are not currently active in the system can be cleared from the alarm list.

Upon alarm reset (if the process no longer exceeds the alarm set point, but the alarm output has not yet reset due to the alarm hysteresis), the alarm reset will ignore the alarm hysteresis. The alarm output will then immediately go to the non-alarm output state.

The Alarm File screen can also be accessed through HOME - MONITOR - ALARM icons. The Alarm File screen displays all current and/or previously acknowledged alarms for any given day, according to time and date of occurrence. The system can store daily alarm files for one year or longer (time based on storage usage for data history). Each time an alarm occurs, it is written to a file. Alarm file names are listed as month - day - year.

- At the Alarm File screen, press the OPEN button to display a dialog box to select any .csv file to view (Fig. 90).

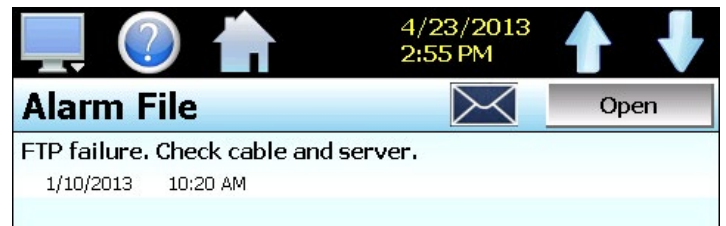

Fig. 90: Alarm File

- The currently opened alarm file can be sent by e-mail to any configured user (Fig. 91). From the Alarm File screen, press the E-mail icon (Fig. 90).

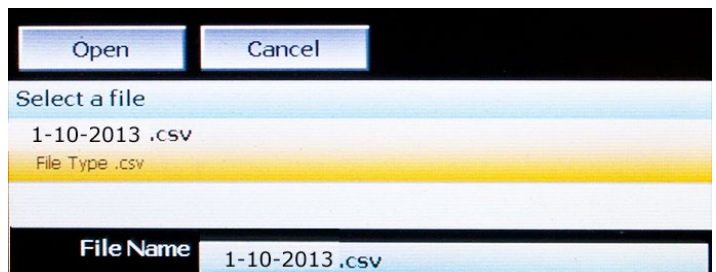

Fig. 91: CSV Alarm File

- A pop-up screen appears with a list of e-mail addresses. Select recipients for the file from e-mail addresses in the list and press SEND (Fig. 92).

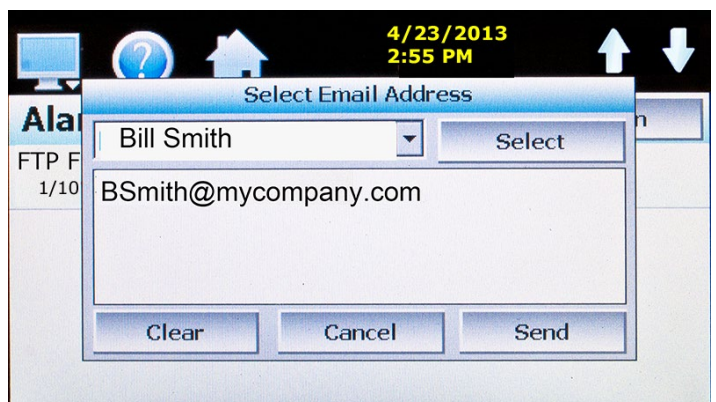

Fig. 92: Email Alarm File

E-mail Function

The e-mail function has the ability to send alarm messages to e-mail and SMS addresses. Up to 30 addresses can be programmed into the system. Each one can be configured to receive e-mails, SMS text messages or both. When an alarm occurs, the System will send an alert to the specified address for each user in the list.

Add E-mail Address

1. The e-mail settings are accessed by selecting HOME - MONITOR - SETTINGS - MONITOR - EMAIL icons (Fig. 93).

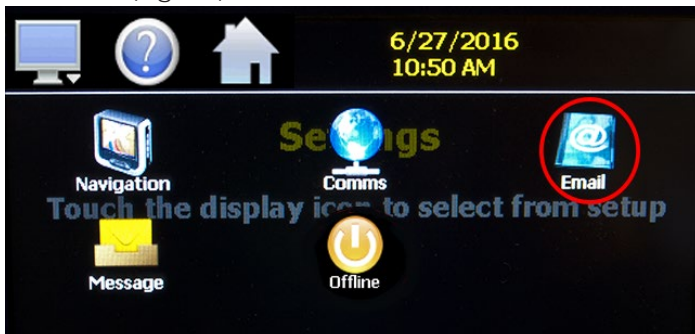

Fig. 93: Email Icon

2. At the E-mail screen (Fig. 94), select the NEW tab to add a new e-mail address.
3. Press on the Name, SMS Number and E-mail Address boxes to enter the relevant information. Use the pop-up keyboard to enter the recipient's Name, E-mail Address and/or SMS Number (up to 50 characters each).
4. Turn on the E-mail Alarm and/or SMS Alarm options to specify which addresses the alarm messages are to be sent to.
5. To add the user's name to the mail list, select the CREATE button.

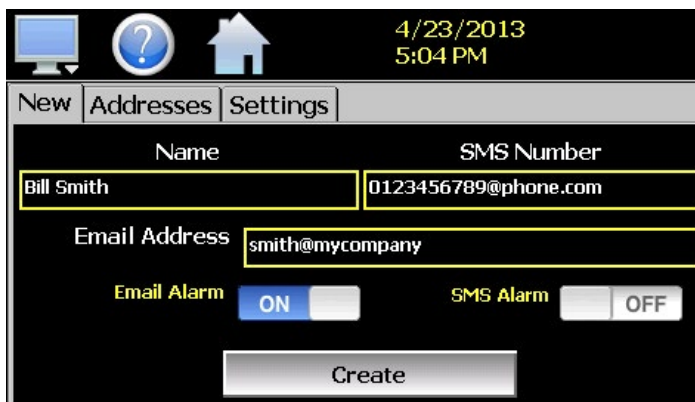

Fig. 94: Add Email Address and SMS

E-mail Address Management and Settings

Note: The SMS address is specific to the service provider. Each service provider has its own unique address; however, the phone number is always the "name" for the address entry. The table below lists some common cell phone providers. Some Internet sites with this information cover most of the providers. When in doubt, contact your service provider for the proper address format.

Cell Phone Provider	Max Message Length	SMS Address to use (where 0123456789 is an example for a 10 digit cell phone number)
AT&T	160 characters	0123456789@txt.att.net
Nextel (Sprint Nextel)	140 characters	0123456789@messaging.nextel.com
Sprint		0123456789@sprintpaging.com
Sprint PCS (Sprint Nextel)	160 characters	0123456789@messaging.sprintpcs.com
T-Mobile	140 characters	0123456789@tmomail.net
Verizon	160 characters	0123456789@vtext.com
Verizon PCS		0123456789@myvzw.com

Viewing E-mail Address List

6. From the E-mail screen (Fig. 94), select ADDRESSES tab to view the list of e-mail addresses entered. Each entry will be shown with the notification method and address associated with it.
7. To permanently delete a user from the list, select the user in the list box. Press DELETE (Fig. 95).

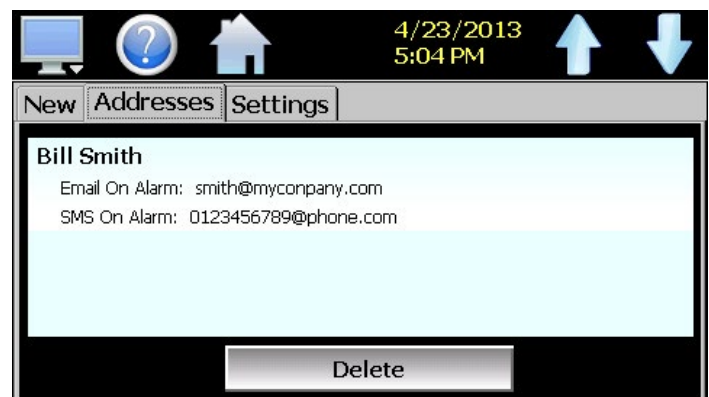

Fig. 95: Viewing Email Address

E-mail Settings

The SETTINGS tab provides access to the e-mail server configuration, which connects to and sends e-mail messages over the Touch screen controller's Ethernet connection. Each field may have up to 50 characters.

1. From the E-mail screen, select SETTINGS tab (Fig. 96).



Fig. 96: Email Settings Screen

Press on the boxes to enter the information required in the table below, using the pop-up keyboard.

LOGIN	Enter the login name required by the System to log in to your company's mail server. You can use your login if one is not set up specifically for the System on your network. Contact your network administrator for assistance.
RETURN ADDRESS	The address on the controller given for your company's mail server. The System does not accept e-mail messages. This field is required for proper e-mail delivery for security/anti-spam purposes. If using your personal login name, your personal e-mail address can be used if one is not set up specifically on the controller on your network. Contact your network administrator for assistance.
PASSWORD	Enter a password (if required by your network server) to send e-mail. Contact your system administrator for assistance.
SMTP Address	Enter the e-mail server address used for sending e-mails. This must be a valid mail server for which the above settings allow the controller access. Contact your system administrator for assistance.
SUBJECT field	Enter a subject line for e-mails and/or SMS text messages. It can be used to provide an identifier to the recipients of the alarm message to know which chamber it is coming from. Note: It is recommended to put some form of entry in this field. It can be left blank; however, many firewalls and spam filters will filter out messages without subject lines. That may prevent recipients from receiving the e-mail.

2. Once all settings have been made, press the SAVE button to begin using the new values and store them. At the next power up, the settings will be retained. The body of the e-mail/SMS text message will contain the description of the alarm condition as it would appear on the alarm screen. If the mail server is down, or System is not

connected to the network, the message will not be sent and a local alarm message on the alarm screen will indicate a transmission failure.

Sending an E-mail Message

Send short e-mail messages to users configured in the System e-mail server.

1. Select HOME - MONITOR - SETTINGS - MONITOR - MESSAGE icons. At the E-mail Message screen (Fig. 97), press the "Compose" button to create a brief message (up to 100 characters) using the pop-up keyboard. When finished, press the "Done" button. The completed message will display in the message window.

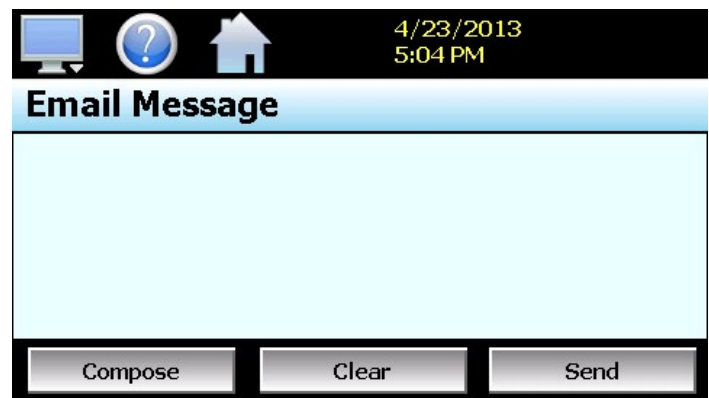

Fig. 97: Email Message Screen

2. Press the "Send" button to select the e-mail recipients to receive the message (Fig. 98). Select recipient from the pop-up list and press Send.

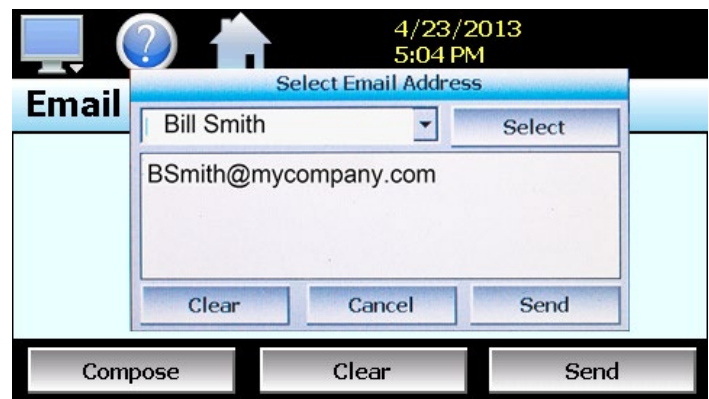

Fig. 98: Send Email

Communication Setting (Admin Task)

The "Comms" screen provides settings for the Modbus serial interface, web server and VNC interfaces. It also provides the Touch Screen controller IP address required for using the VNC or web server interfaces.

- To access the communication settings, select HOME - MONITOR - SETTINGS - MONITOR - COMMS icons (Fig. 99).
- The COMMS screen appears (Fig. 100). See the table below for explanation of the fields.

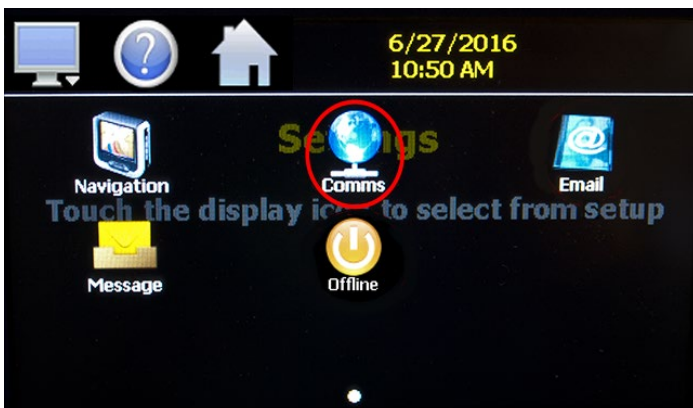

Fig. 99: COMMS Icon

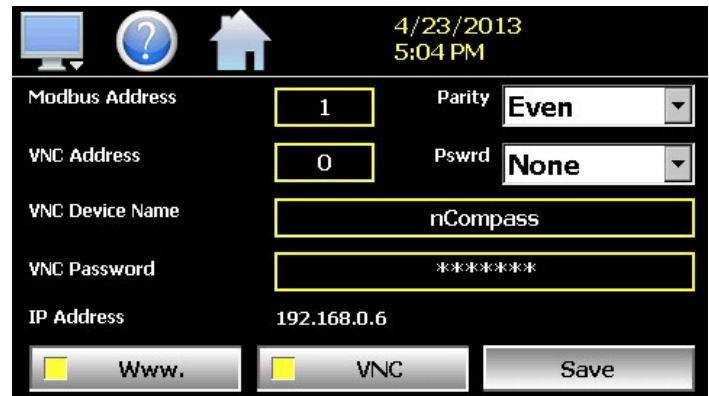

Fig. 100: COMMS Screen

- Tapping on any of the COMMS screen yellow boxes will produce a keypad or keyboard to input the settings.

Comms Screen Settings	Description
Modbus Address and Parity	Used to configure the serial interface for user communications. Valid addresses are 1 to 31. The parity setting is only available for the standard Touch Screen controller LC interface and allows the serial port to be set for Even, Odd or no parity (None). If the controller is configured to provide the simulated Watlow F4S/D communications interface, the parity selection will not be shown.
VNC Address and Password	Sets access rights to the Touch Screen controller VNC server. Valid addresses are from 0 to 255. The VNC password selection defines the connection mode for the server. The selections are "None" and "VncAuth" which requires users to enter the password when connecting to Touch Screen controller over the VNC interface. IMPORTANT: When multiple Touch Screen controllers are connected to a single router (DHCP server), it is imperative that each Touch Screen controller have a different VNC address. If multiple Touch Screen controllers have the same VNC address, network errors may result causing the VNC server to shut down or cause controllers to "lock-up" and become non-responsive requiring the unit to be power cycled in order to return to normal operation.
VNC Device Name field	Used to enter a name (up to 35 characters) that can better identify Touch Screen to users logged into the VNC interface. The name entered here will be used on the VNC header window on a PC, so that if multiple VNC clients are open to different systems, each one can be identified.
VNC Password	Used to enter the password (up to 20 characters) that a user must enter for the VNC interface to connect to Touch Screen controller if the VNC password is enabled.
www. (web server) push button	Used to enable or disable the web server interface.
VNC server push button	Used to enable or disable the VNC server interface.
IP Address Field	A static field that provides the IP address of Touch Screen controller, which is required for connecting over the VNC and web server interfaces. For more information on Device IP and other LAN information refer to "Communications (Admin Task)" on page 45. NOTE: Any changes made to the above settings must be saved in order for them to take affect. When changes are completed, press the 'Save' button, and then cycle power to the controller. The new settings will only take affect when the Touch Screen controller first boots up.

Clock Settings (Admin Task)

The Touch Screen controller system date and time, time zone and daylight savings times can be adjusted.

1. Select HOME - MONITOR - (swipe screen) SETTINGS - MONITOR - OFFLINE - Select YES - MONITOR - CLOCK icons (Fig. 101).

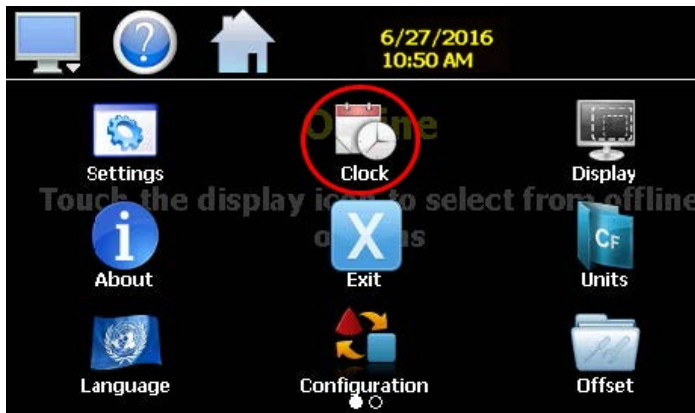

Fig. 101: Clock Icon

Adjust Time Tab

2. At the CLOCK screen (Fig. 102), select ADJUST TIME tab under the Set/Clock menu. The current date and time will be displayed in the thumb wheels as shown below.
3. To make adjustments, scroll each time wheel to adjust the month, day, year, hour, minutes, seconds and AM/PM selection. Once all adjustments have been made, press SAVE to set the system clock to the date and time entered.



Fig. 102: Adjust Time Tab

Time Options Tab

4. Select the TIME OPTIONS tab (Fig. 103) to configure the time zone and national time server clock settings. If the Touch Screen controller is

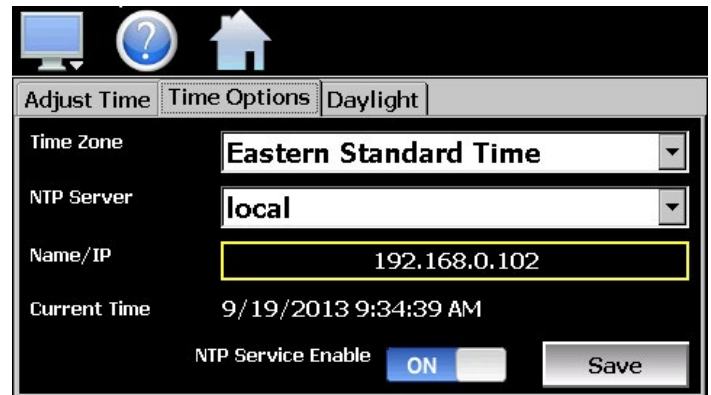

Fig. 103: Time Options Tab

connected to the internet, these settings can be used to have the controller automatically synchronize its time with one of the nationally provided time servers.

5. To enable the national time server, select your time zone and which time server you wish to use from the drop down menu selections. Turn on the NTP SERVICE ENABLED option and press the SAVE button. The Touch Screen controller will then synchronize its time with the selected national time server at 2:00 AM each day.
 - A. If the controller is not connected to the internet, a local alarm message will be shown on the alarm screen – “NTP Failure. Check cable and server” – to indicate that the time server could not be located.
 - B. If an active internet connection is not available, or company policy prohibits internet access, the controller can be configured to use a local time server instead of one of the national time servers. To configure the use of a local time server, select “local” from the NTP server list. When selected, the “Name/IP” entry field will be shown. The computer name or IP address of the computer running the local timer server on the LAN can then be entered. The Touch Screen will then contact the local computer in order to synchronize time.
 - C. NOTE: The steps required to configure and provide NTP service from a computer on the LAN is outside the scope of this manual. Contact your network administrator for assistance.

Daylight Tab

6. Select the DAYLIGHT tab (Fig. 104) to configure daylight savings time options. Set the start date and end date for daylight savings time.



Fig. 104: Daylight Tab

- A. If your locale utilizes daylight savings time, set the start/stop dates for daylight savings. Turn on the DAYLIGHT SAVINGS ENABLE option. Press SAVE to store the settings. The Touch Screen controller will then automatically update its clock for daylight savings time.
- B. NOTE: If the NTS time server setting is enabled, and the selected time zone uses daylight savings time, daylight savings must be properly configured and enabled or the clock will not show the correct time.

Language (Admin Task)

The Language screen is used to select the language for all of the online help, menus and most static display fields. The keypad will remain in English, so all user text entries will still be in the English language.

1. Select HOME - MONITOR - (swipe screen) SETTINGS - MONITOR - OFFLINE - Select YES - MONITOR - LANGUAGE icons (Fig. 105).

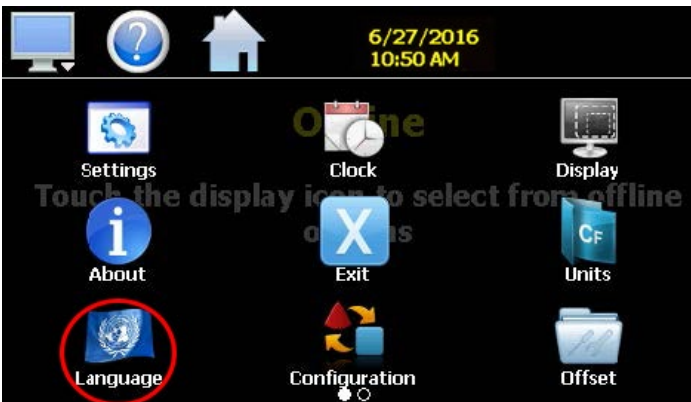

Fig. 105: Language Icon



Fig. 106: Language Screen

2. At the Language screen, select the desired language and toggle ON (Fig. 106).

Available language selections include:

Afrikaans	Albanian	Arabic
Basque	Belarusian	Simplified Chinese
Traditional Chinese	Czech	Danish
Dutch	English	Finnish
French	German	Greek
Hebrew	Hungarian	Icelandic
Italian	Japanese	Korean
Norwegian	Polish	Portugese
Russian	Spanish	Swedish
Turkish		

DISCLAIMER: English is the default language for the Touch Screen control system. All other language selections are provided through internet translation of the English language. MAC Medical does not guarantee the accuracy or validity of alternative language selections and shall not be liable for any damages or losses, whether direct, indirect, incidental, special, consequential or any other damages for misinterpretation of other languages.

Offset Calibration (Admin Task)

The Touch Screen controller loop control is calibrated at the factory before shipment; however, they can be recalibrated in the field with the use of proper calibration equipment. While the basic calibration of the unit is highly stable and set for life, the input offset calibration provides the means for the end user or OEM to offset the permanent factory calibration. Typically reasons for applying this offset may include the need to match a particular reference standard, to match the calibration to a particular transducer or sensor or to remove long-term drift in the factory set calibration.

The input offset calibration provides a two-point offset; a low point offset and a high point offset. The two-point offset constructs a straight line (linear calibration) between the two points. To ensure greatest accuracy, it is best to calibrate with the two points at the minimum and maximum operating ranges of the system.

1. Before entering OFFLINE set up, manually stop any data logging by going to DATA and switching off the Data button.
2. Select HOME - MONITOR - (swipe screen) SETTINGS - MONITOR - OFFLINE - Select YES - MONITOR - OFFSET icons (Fig. 107)

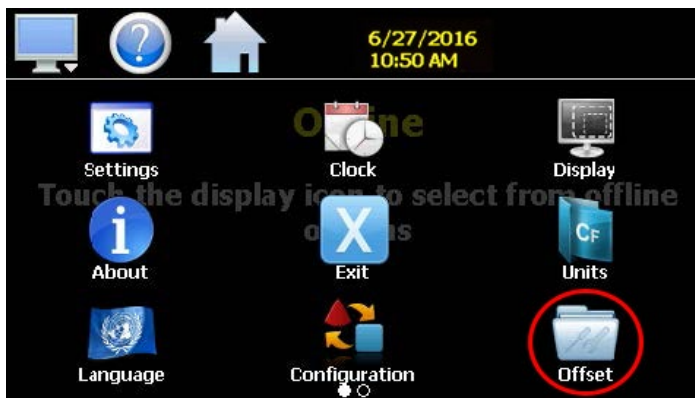

Fig. 107: Offset Icon

3. At the Input Offset screen (Fig. 108 - our example is for a single loop), begin calibration by sending the low signal input to the loop input. If the process value does not match the reference signal, adjust the low point offset so that the process value matches the reference input signal.

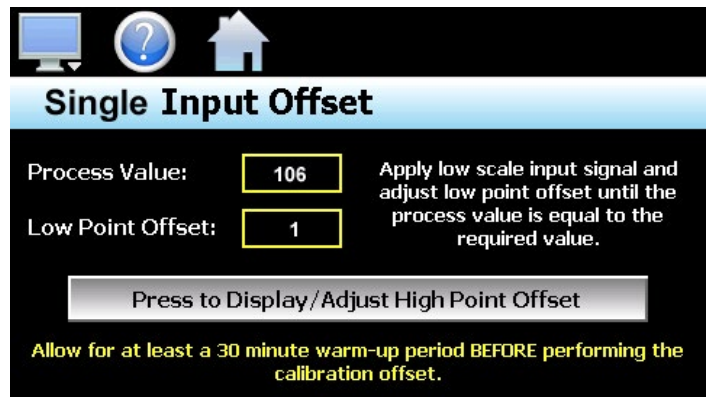

Fig. 108: Input Offset Screen

4. To adjust the low point offset, press on the LOW POINT OFFSET box. A keypad will appear (Fig. 109).

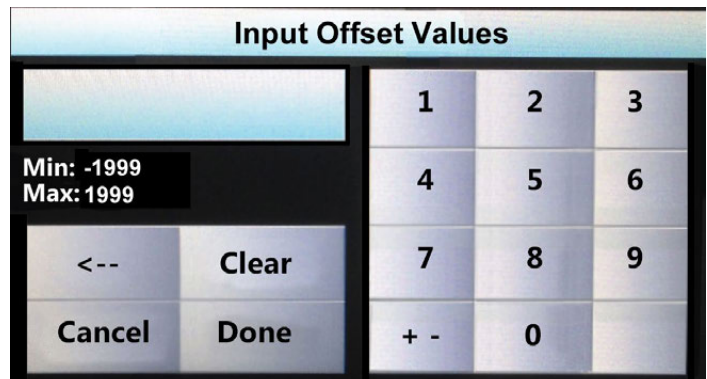

Fig. 109: Input Offsets Value Keypad

5. Press the PRESS TO DISPLAY/ADJUST HIGH POINT OFFSET to switch to the high point offset and then apply the high signal input to the loop control (Fig. 108).
6. If necessary, adjust the high point offset by selecting the HIGH POINT OFFSET box in order to make the process value match the reference signal.

Display Settings (Admin Task)

The Display screen provides access to the touch screen calibration utility, back light settings and alarm volume.

1. Select HOME - MONITOR - (swipe screen) SETTINGS - MONITOR - OFFLINE - Select YES - MONITOR - OFFSET icons (Fig. 110)

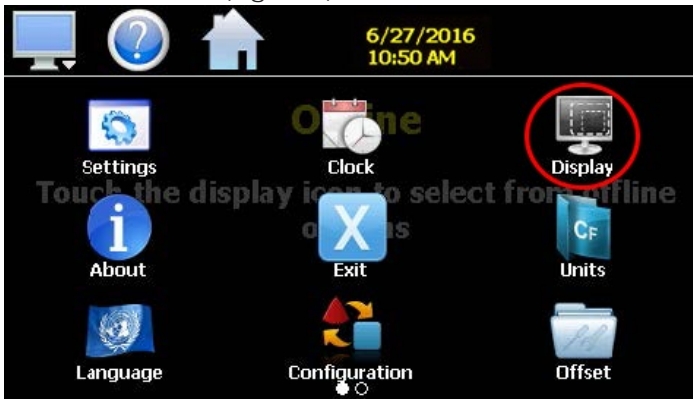

Fig. 110: Display Icon

Alarm Volume

At the Display Screen, the Alarm Volume adjusts the loudness of the internal alarm buzzer of the Touch Screen when activated under an alarm condition. The volume can be set from 0 (off) to 100.

2. To edit the alarm volume, touch the entry field and enter the desired volume level on the pop-up keypad. To test the buzzer, press ALARM TEST (Fig. 111).

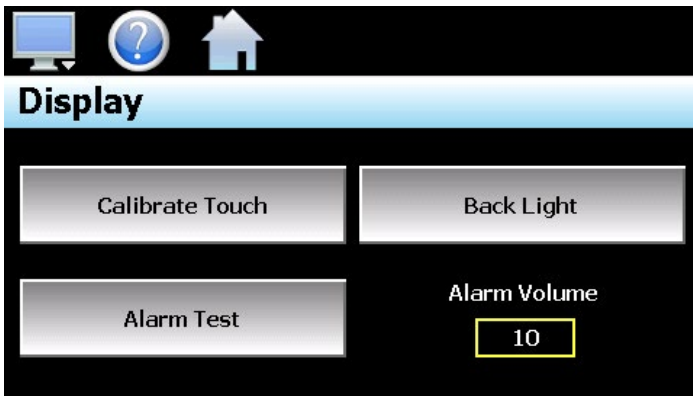

Fig. 111: Display Screen

Calibrate Touch

After extended use and many hours of operation, it may be necessary to recalibrate the touch screen of the Touch Screen. A typical sign that the screen may be out of adjustment is inaccurate responses when attempting to press buttons, check boxes or adjust fields on the display.

3. To remedy this, from the DISPLAY screen, press CALIBRATE TOUCH. An alert message will appear stating that the application will be disabled to perform the calibration procedure.
4. Press YES to continue (Fig. 112).

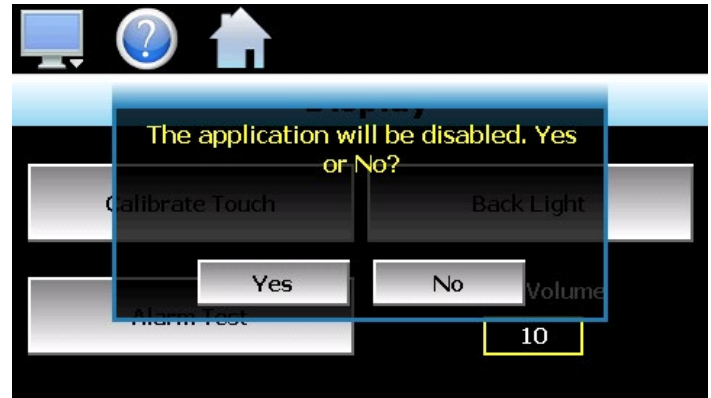

Fig. 112: Display Application Yes/No

5. The calibration utility will start and crosshairs will appear on the screen (Fig. 113). At each crosshair position, touch the screen at the center of the crosshairs. Repeat this for each position in order to set the calibration. The calibration requires five points, the center and four corners.

Note: It is recommended to use your finger rather than a stylus when calibrating the screen. The touch response will be more fluid after calibrating it with your finger.

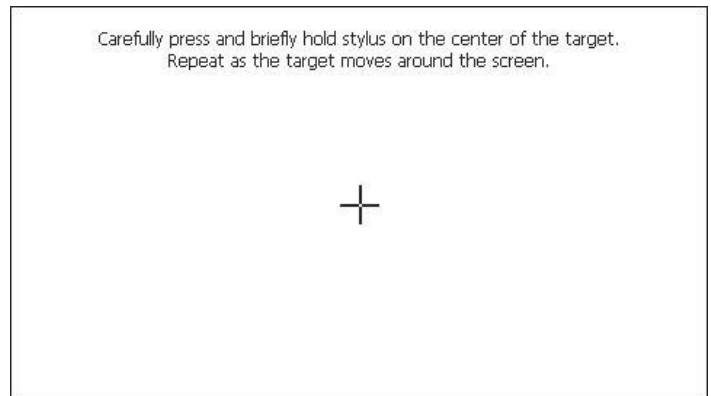

Fig. 113: Calibration Crosshair Screen

Once complete, a notification message appears stating that the new calibration settings have been measured and to touch the screen to register the new calibration data.

6. Touch anywhere on the screen to close the window and return to the Touch Screen application to resume normal operation.

Backlight Settings

The backlight settings allow adjustment of the screen brightness as well as setting a time period for dimming the backlight after a period of inactivity to extend the life of the display.

- To adjust the backlight settings, from the DISPLAY screen press the BACK LIGHT button (Fig. 111). An alert message will appear stating that the application will be disabled to enter the backlight settings, press YES to continue.
- From the DISPLAY PROPERTIES screen, select the BACKLIGHT tab (Fig. 114).

Note: The checkboxes on the Backlight tab for “Automatically turn off backlight while on battery power” and “Automatically turn off backlight while on external power” have no affect on backlight operation and should be left unchecked.

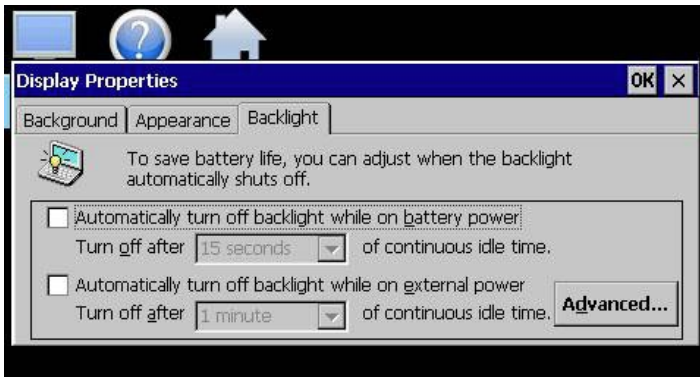

Fig. 114: Backlight Tab

- Press the ADVANCED button to access the settings for the backlight (Fig. 115).

Adjust the display brightness during operation with the “ON” slider. The default setting is 100. Use “OFF” slider to adjust the brightness of the display during periods of inactivity. The default setting is 10. **Note:** a zero (0) setting does not completely turn off the backlight.

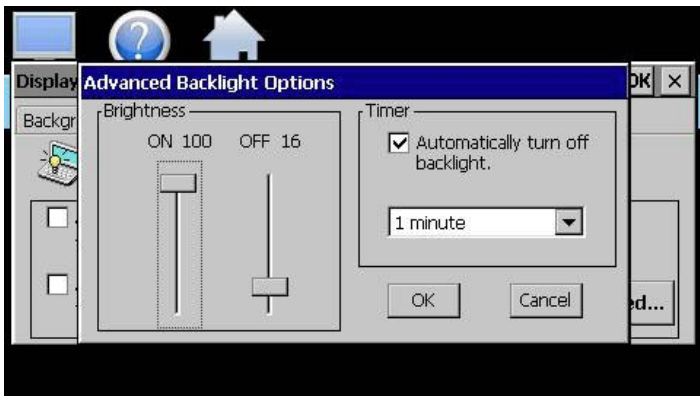

Fig. 115: Advanced Backlight Options

- To enable the backlight dimming function, check the “Automatically turn off backlight” checkbox
- Set the delay time using the drop down selection box. The delay time can be set at fixed intervals from as little as 15 seconds to as long as 30 minutes.
- Once all settings are complete, press OK.
- Then press OK at the top right of the DISPLAY PROPERTIES screen to return to the Touch Screen application and begin normal operation.

Configuration (Admin Task)

The Configuration utility allows backing up of the entire Touch Screen configuration and to save it to a file for “safe keeping” in case of system damage. The utility allows configuration of the Touch Screen by selecting from a list of preconfigured setups that could be created and saved on a USB memory device for loading a configuration to a new Touch Screen system.

Important: Do not import configuration files that are not intended for use with the current hardware configuration of the Touch Screen as unexpected operation may result.

- Select HOME - MONITOR - (swipe screen) SETTINGS - MONITOR - OFFLINE - Select YES - MONITOR - CONFIGURATION icons (Fig. 116).

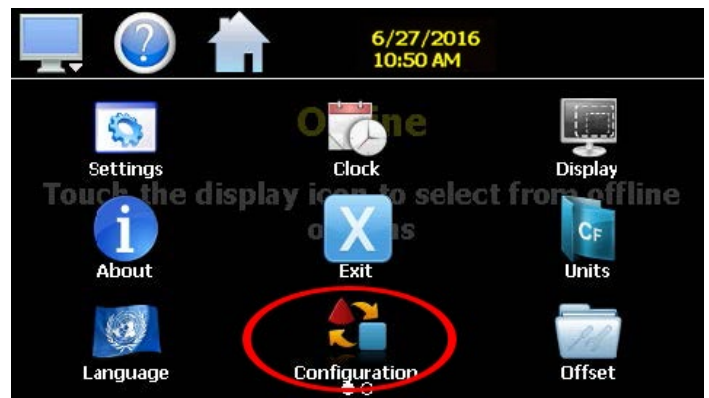

Fig. 116: Configuration Icon

- The CONFIGURATION screen appears (Fig. 117). The table on page 44 explains the button options and their functions.

Note: The configuration functions do not affect the VNC server configuration. The enable state, VNC address, device name and password fields must be manually changed as these settings are specific to each device and must be set independently for proper VNC server operation over a network.

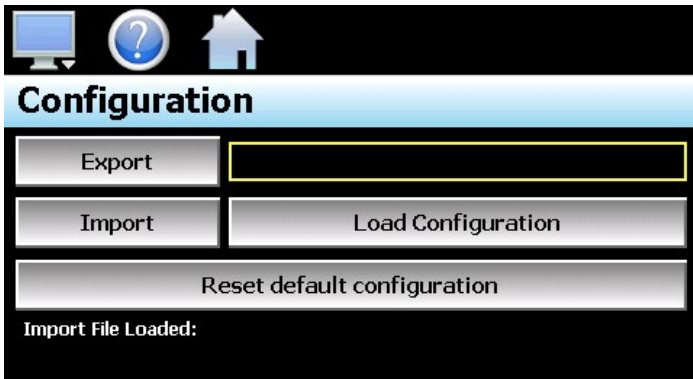

Fig. 117: Configuration Screen

Export	Writes Touch Screen configuration data to a USB memory device. The export file function uses the name entered in the text field to the right of the export button to create a directory on the memory stick with that name containing the configuration data. Enter the filename (up to 10 characters), which permits multiple configurations to be identified and saved for later retrieval. The export file saves with a name format of "cfg_filename_mm_dd_yy_hh_mm_ss" to identify the configuration according to the date/time it was created. This prevents multiple configuration files with the same name from overwriting previous files. Also allows identification of a Touch Screen backup for reconfiguration to a previous date if multiple backups are created.
Import	Writes configuration data to the Touch Screen from the currently loaded file. To load a configuration file, the USB memory device must first be inserted into the USB port.
Load Configuration	Shows a list of available configuration files from the memory stick. Select the desired file from the list and press "Open" to load the file. Once the file is loaded, pressing IMPORT will begin the process. Note: when the import is complete, cycle power to the Touch Screen to load the new configuration data into runtime memory for proper operation.
Reset Default Configuration	Resets to the default configuration to clear the current Touch Screen configuration, resetting the system back to default values. Clears all user and/or OEM configuration values and returns the system to an "as new" factory state allowing the system to be configured from scratch. This function provides a means to start over in the event that the system configuration has been altered to an unknown state and is not operating properly, and a known good configuration is not available to import. Instead of searching every setting of every feature to determine where the configuration error exists, RESET clears the system so that it can be reconfigured from a clean slate.

IMPORTANT: It is highly recommended that the administrator back up the Touch Screen configuration and save it to a file in case of system malfunction or to return to the OEM configuration.

Exit Application (Admin Task)

For daily operation, the Touch Screen is normally shut down by just switching off the power. Powering back on will bring up its normal saved configuration.

The EXIT Application screen quits the Touch Screen runtime software and returns to the default CE.Net operating system. ONLY administrators in charge of system configuration should do this task due to the danger of editing or removing files.

1. Select HOME - MONITOR - (swipe screen) SETTINGS - MONITOR - OFFLINE - Select YES - MONITOR - EXIT icons (Fig. 118).

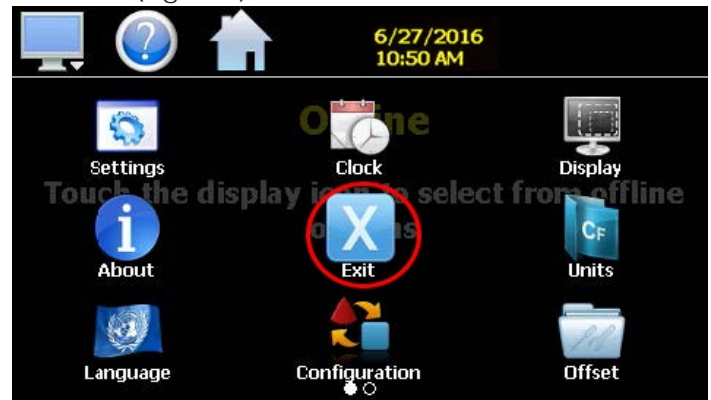

Fig. 118: Exit Icon

2. The EXIT screen appears (Fig. 119). The table below explains the button options and their functions.

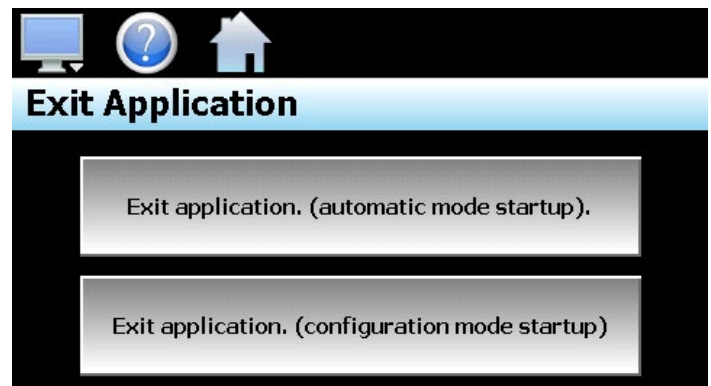

Fig. 119: Exit Screen

Automatic mode startup option (Preferred)	Returns the Touch Screen to normal operation on the next power up.
Configuration mode startup (Avoid)	Starts the Touch Screen configurator program on the next power up so that the user can access control loop and Touch Screen runtime settings. Selecting this function will require either a new configuration to be saved or reloading of the original configuration to restore it.

Communications (Admin Task)

This section provides instructions on how to use the Touch Screen communication interfaces. As a standard, the Touch Screen is equipped with both an Ethernet interface and an RS232 serial interface for user communications.

Ethernet Communications

The Touch Screen provides two forms of Ethernet communication interfaces for monitoring and controlling the system across a network. The web server interface provides a monitor-only connection, while the VNC server interface allows a user to manipulate and control the Touch Screen controller remotely by viewing the Touch Screen display directly on their PC screen.

NOTE: In order to use Ethernet communications, the Touch Screen must be properly connected to a network. To connect the Touch Screen to a network, connect the Touch Screen's Ethernet port to your network using a standard CAT5 cable connection. Note that after connecting the network cable, it may be necessary to cycle power to the Touch Screen in order for it to obtain a valid IP address.

Configuring the Touch Screen Network

In order to connect to the VNC server or web server of the Touch Screen, you will need to know the IP address of the Touch Screen on the network. It is important to note that if using DHCP in your network router, the Touch Screen address may change on re-power requiring you to access the Touch Screen directly in order to obtain the new IP address. This could result in VNC/web server connection issues if the address regularly changes.

Therefore, it is recommended that the IP address for the Touch Screen be assigned as a fixed (static) address. This ensures that the address will not change once it has been set. This can be done in one of two ways. The first is by setting up the control LAN router to assign the same IP address whenever it detects the Touch Screen device on the network via its own identifier; its MAC address.

The other option is to configure the Touch Screen to use a fixed IP address and disable the DHCP addressing function of its network interface. When using this method, it is important to make sure that the address being assigned to the Touch Screen is not used by any other device on the network. If another device is using the same address, the VNC and web server interfaces will not function correctly. It is recommended that this method of static IP

assignment be used as it removes the IP address lease renewal process that would be performed by the control LAN router if DHCP was used.

The lease renewal process performed by the control LAN router can cause the VNC server in the Touch Screen to shut down due to an issue in the renewal process. It could be caused by something in the router firmware or configuration of the router itself. Due to the numerous brands and models of routers available, and the dynamic nature of their use, attempting to resolve the issue is beyond the scope of this manual. Therefore, the use of static IP addressing removes this from the equation, providing the most robust network solution.

Obtaining the Touch Screen MAC Address

The MAC address can be obtained from the network connections screen. In order to access the screen, exit the Touch Screen application.

1. Press the EXIT icon (Fig. 118) under the OFFLINE setup menu.
2. At the Exit Application screen (Fig. 119), press the EXIT APPLICATION (AUTOMATIC MODE STARTUP) button.
3. Follow the on-screen prompts to stop the application and exit to the Windows CE desktop.

Note: The text, "System Startup Please Wait..." on the desktop is static and does not indicate that any application is going to start at this time. It is used as a "placeholder" prior to the Touch Screen runtime or configuration application starting during normal power-up sequences so that the user is informed that an action is taking place.

4. From the desktop, double tap the hidden icon at the top left of the screen (circled in red) to provide access to the taskbar application (Fig. 120).



Fig. 120: System Startup after Exit

5. Press SHOW TASKBAR (Fig. 121) to show the taskbar and then press QUIT to exit the taskbar application



Fig. 121: Show/Hide Taskbar Screen

6. Next, double-click on the network connections icon (circled in red) to open the network connection information window (Fig. 122).



Fig. 122: Select Network Connections Icon

7. Two tabs will be provided; one for IP Information and the other for IPv6 Information. To obtain the MAC address, press the 'Details...' button on the IP information tab.
 - A. The MAC address (Fig. 123) is displayed as the first item (Physical Address). Once the address has been recorded, close the network information windows and cycle power to the Touch Screen in order to restart the system and return to normal operation.

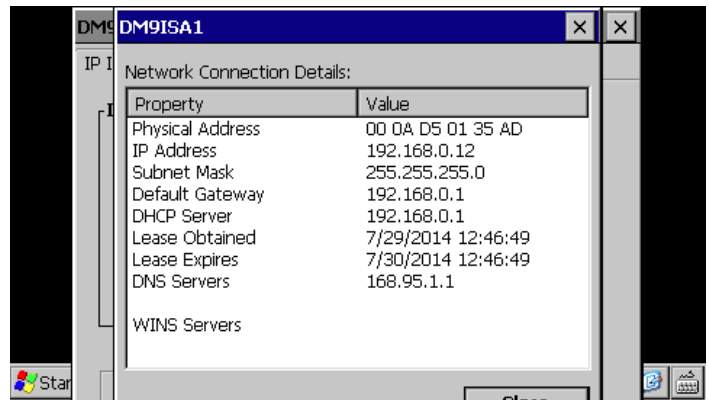

Fig. 123: IP Information tab screen

Setting a Static IP Address

To set a static IP address for the Touch Screen on a network, it is necessary to exit the Touch Screen application and enter the 'Network and Dial-up Connections' settings of the CE operating system.

Important: It is recommended that only personnel charged with configuring and maintaining Touch Screen perform this procedure. Do not alter, change or delete any other files or settings of the system. Doing so may render the Touch Screen inoperable.

1. To exit the Touch Screen application, press the EXIT icon under the OFFLINE setup menu.
2. At the "Exit Application (Admin Task)" on page 44, press the EXIT APPLICATION (AUTOMATIC MODE STARTUP) button.
3. Follow the on screen prompts to stop the application and exit to the Windows CE desktop.

Note: The text, "System Startup Please Wait..." on the desktop is static and does not indicate that any application is going to start at this time. It is used as a "placeholder" prior to the Touch Screen runtime or configuration application starting during normal power-up sequences so that the user is informed that an action is taking place.

4. From the desktop, double tap the hidden icon at the top left of the screen (Fig. 124 - circled in red) to provide access to the taskbar application.



Fig. 124: System Startup after Exit

- At the next screen, press "SHOW TASKBAR" to show the taskbar. Then press QUIT to exit the taskbar application.
- Enable the CE keyboard (Fig. 125) so that it will be available to enter in the IP address. **Enable it now** or the taskbar cannot be accessed later once in the Ethernet Drivers screen. To enable the keyboard, touch the keyboard icon at the lower right of the taskbar. Select 'Keyboard' from the menu to make the keypad visible.

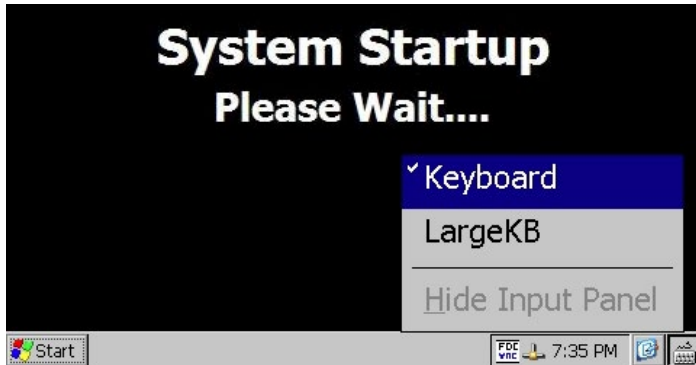

Fig. 125: Activate CE Keyboard

- Next, press the Windows Start button and select 'Settings' and then 'Network and Dial-up Connections' to show the connections window (Fig. 126).

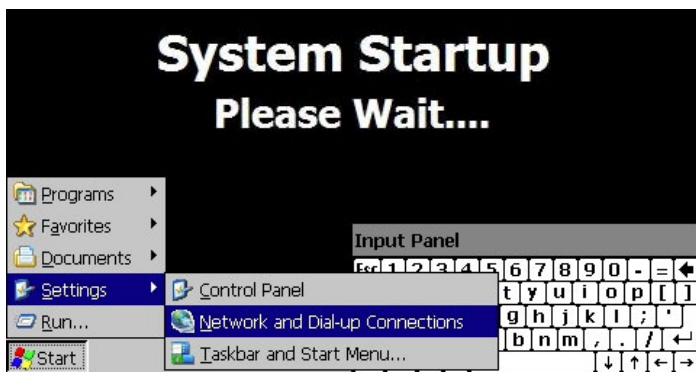

Fig. 126: Window CE - Select Network Connections

- From the 'Connection' window, double tap the connection icon to select the current network connection to enter its property window. DO NOT create a new connection. The 'Ethernet Drivers' property window allows setting the IP address and naming primary and secondary DNS and WINS servers from the "Name Servers" tab if necessary. Select 'Specify an IP address' and enter in the desired IP address, subnet mask and default gateway. Move the keyboard around the screen to position it where needed to access the different fields.

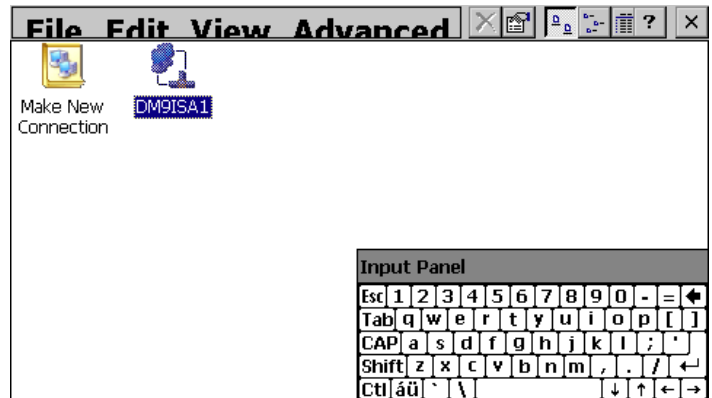

Fig. 127: Connections Window

- Once complete, press OK button at the top right of the window to close the 'Ethernet Drivers' window (Fig. 128).
- Close the Connection window by pressing the 'X' button at the top right of the window (Fig. 127).

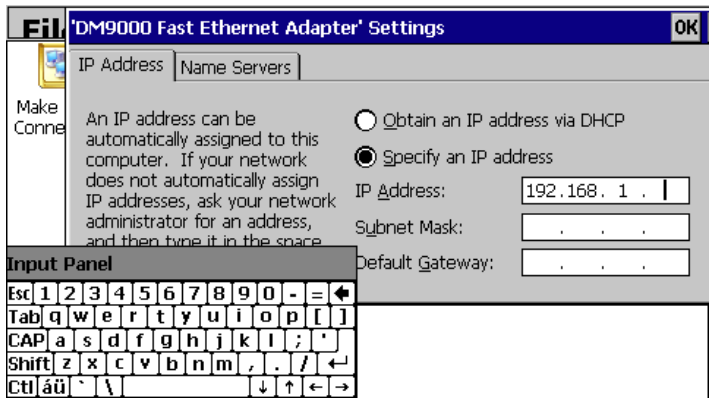

Fig. 128: Ethernet Drivers Window

- At the "System Startup, Please Wait..." screen, double tap the hidden icon to access the taskbar. Hide the keyboard by pressing the keyboard button and select 'Hide Input Panel.' DO NOT cycle power to the Touch Screen at this time. Wait approximately 2 minutes before removing power. This allows time for the Windows CE operating system to save the new network settings to the registry so that it uses the settings on the next reboot.
 - If power is cycled too soon, the network settings will revert back to the previous settings on the next power up. Once the 2 minute time period has elapsed since updating the network settings, cycle power to Touch Screen to restart the system and return to normal operation with the new network settings.

Using the Web Server

The Touch Screen web server allows a user to remotely monitor operations anywhere via a PC's standard web browser. When enabled, the web server provides a detailed status page of the current operating conditions.

You must use the assigned IP address to access the Touch Screen. The IP address is shown on the communications screen and is also included in the notifications list. Write down the IP address so you will have it later to enter into your web browser

1. The web server can be enabled and disabled by pressing the Www button on the communications screen under the COMMS setup menu.
2. To access the COMMS setup menu, select HOME - MONITOR - SETTINGS - MONITOR - COMMS icons (Fig. 129).

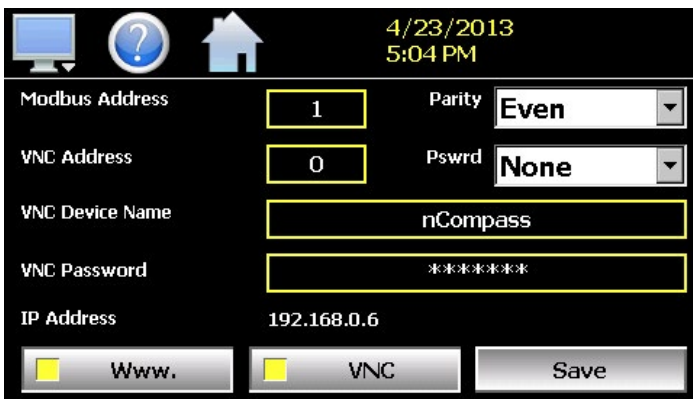

Fig. 129: COMMS Screen

3. To access and view the Touch Screen web page, enter its link in your PC's browser address window - for example: [http://\"IPaddress\"/yourcompany.html](http://\). The web page updates automatically every 30 seconds and provides information on each individual control loop and alarm status.

Note: Contact your network administrator prior to enabling the web server of the Touch Screen. Company policy may prohibit the use of web servers for security reasons. MAC Medical is not responsible for the use of, nor makes any claims as to the security of the web server interface over your network. The use of the web server is the responsibility of the end user.

Using the VNC Server

The Touch Screen VNC server allows a user to remotely monitor and control Touch Screen by directly viewing and manipulating the touch screen over the network. You must use the assigned IP address and VNC port number to access Touch Screen. The IP address is shown on the communications screen and is also included in the notifications list. Write down the IP address and port number so you will have it to enter into your VNC viewer.

There are many VNC viewers available for both PC and tablet use. Due to the ever changing market and availability of such applications, it is not possible to test them all for compatibility or provide assistance for their use with Touch Screen. It is the responsibility of the end user to test the chosen VNC client for compatibility with Touch Screen prior to putting the unit into service. If the VNC client viewer has compatibility issues with Touch Screen, it can cause the VNC server to stop responding and/or shut down, requiring power to be cycled to Touch Screen in order to reboot the system and restart the server.

MAC Medical recommends the use of RealVNC's viewer. It has been tested for compatibility with Touch Screen and a free version can be obtained from <http://www.realvnc.com/> for PC/MAC use. RealVNC does offer a version for the iPad that can be obtained through the App Store for a small fee.

The App Store also offers a free VNC client called Remotix for the iPad. It has also been tested for compatibility with Touch Screen.

Note: Contact your network administrator prior to enabling the VNC server of Touch Screen. Company policy may prohibit the use of VNC servers and/or viewers for security reasons. MAC Medical is not responsible for the use of, nor makes any claims as to the security of the VNC server interface over your network. The use of the VNC server is the responsibility of the end user.

Recommended VNC Viewer Settings (PC/MAC)

This section applies to setup of the recommended RealVNC viewer for PC/MAC. These settings have been tested and evaluated in order to provide the best performance and quickest response to user input when using the VNC viewer with Touch Screen.

After installing the VNC viewer software, it is recommended that the following changes be made to the default viewer settings.

1. To begin, from a PC, start the VNC viewer. Click on the "Options" button to open the "VNC Viewer - Options" window (Fig. 130).

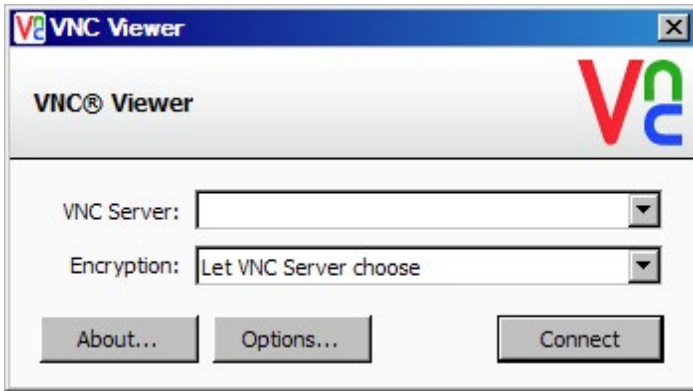

Fig. 130: VNC Viewer

2. Click on the "Advanced" button at the bottom left of the window to display the advanced setup options.
3. At the VNC View - Options screen (Fig. 131), click on the "Display" tab. Toggle the scaling to "No scaling." Check the checkbox for "Adapt to network speed (recommended)."

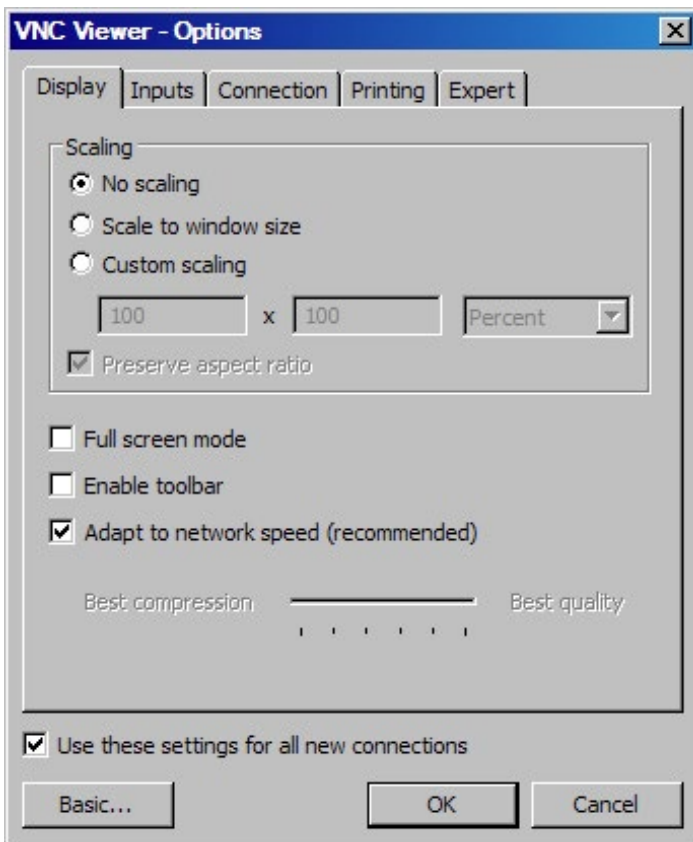

Fig. 131: VNC Viewer - Options - Display Tab

4. Next, select the "Inputs" tab (Fig. 132) and deselect all entries except for "Enable mouse input" and "Rate-limit mouse move events." The "Inputs" drop down selection box will automatically change to "Custom" when the settings are made.

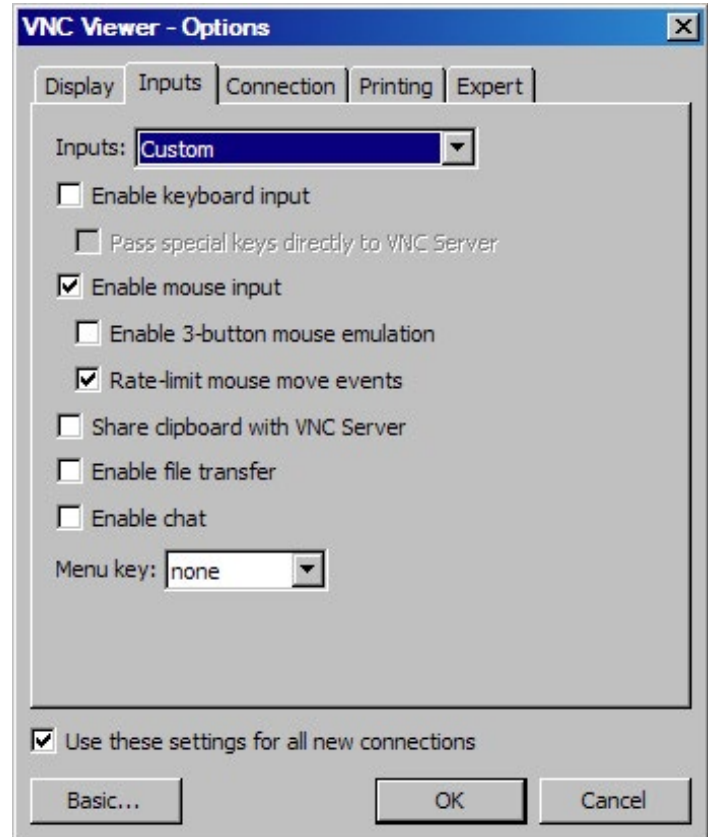

Fig. 132: VNC Viewer - Options - Input Tab

5. Proceed to the Expert' tab (Fig. 133). Scroll down the list of settings until you find the "PreferredEncoding" and "Protocol3.3" options.
 - A. Set the preferred encoding to Hextile and the Protocol 3.3 option to true. Verify that the "Use these settings for all new connections" checkbox at the bottom of the window is checked and click the OK button. This will set the selections to the default start settings for the VNC viewer.

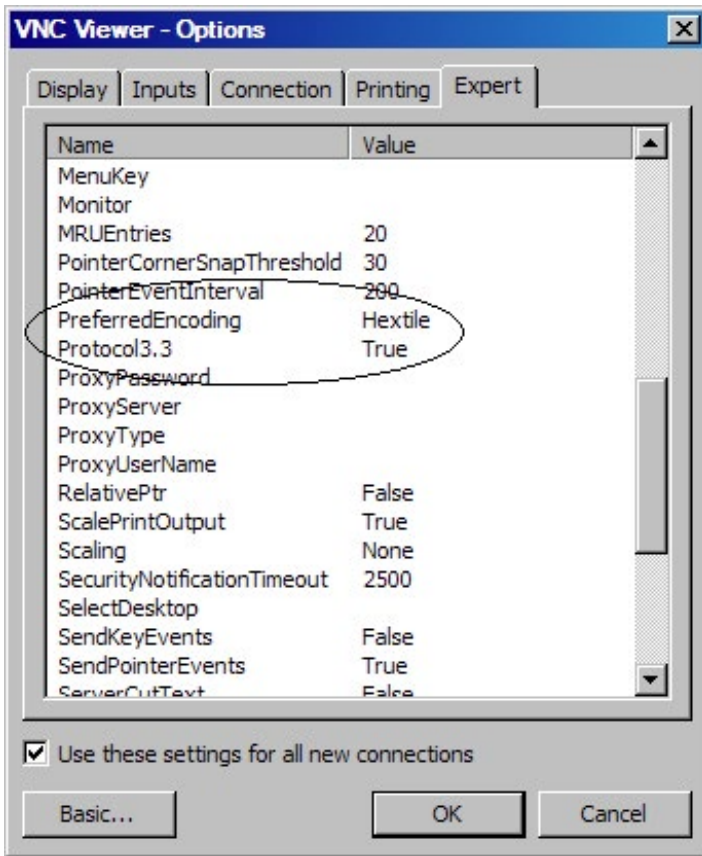

Fig. 133: VNC Viewer - Options - Expert Tab

Recommended VNC Viewer Settings for Tablets

The VNC clients for tablets have been found to offer limited flexibility for use with Touch Screen. Most clients have default settings requiring security to be enabled on the server in order to connect. If you have trouble connecting with a VNC viewer through an iPad, iPhone or even an Android based phone, start by enabling the security on the Touch Screen VNC server and be sure to enter those settings in the client viewer.

Color and encoding options can also affect the connectivity. If the client offers the option, leave color and encoding options to 'automatically detect' or 'server decides.' If the client is still unable to connect, try default encoding of Hextile and set the color option to limited colors such as 256 bit color. MAC Medical does not write or create VNC clients (third party software), so final selection of client and testing is the end user responsibility. The following settings are provided as an example for the Remotix client for the iPad. When adding a Touch Screen server to the Remotix client, use the following settings. Note that the VNC server in Touch Screen must have security enabled in order for this client to connect.

Connection Type: VNC
 Host/IP: IP address of Touch Screen
 Port: VNC address of Touch Screen (5900 = 0, 5901 = 1, etc...)
 Use SSH Tunnel: Off
 VNC Authentication: VNC Password
 VNC Password: VNC password of Touch Screen
 VNC Server Type: AutoDetect
 Operating System: Windows
 Preferred Encodings: Hextile
 Color Depth: 16 bits

Accessing Touch Screen through a VNC Viewer

The following examples are based on the use of the RealVNC viewer for PC/MAC.

1. Once the default settings have been entered, enter the IP address and port number for Touch Screen, and click the 'Connect' button to access Touch Screen over the network.
 - A. **Intranet Example:** If the IP address assigned is 192.168.3.5 and the configured VNC Address is 1, from the PC's VNC Viewer address field, enter "192.168.3.5:1" to access the device (address 1 relates to port 5901, address 2 to port 5902, etc., which is the port opened by the VNC interface in order to allow communications with Touch Screen over the network (Fig. 134).

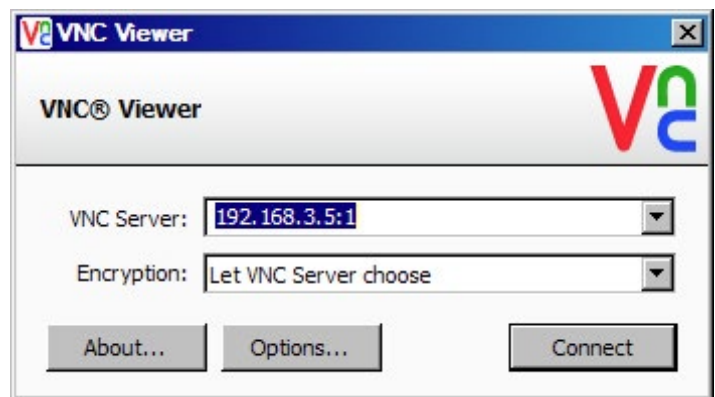

Fig. 134: VNC Viewer - Intranet

- B. **Internet Example:** Internet connection typically requires a qualified network System Administrator. Typically a permanent IP address and specific port address are assigned to Touch Screen; support on this action is beyond the scope of this guide. Consult your network system administrator for assistance in setting up an Internet connection (Fig. 135).

- C. If the IP address of the LAN is 69.216.64.69 and the configured VNC Address is 1 (port 5901 has been opened and assigned to this specific Touch Screen controller), from the remote PC (outside of the site Servers LAN), in the VNC Viewer address field enter '69.216.64.69::5901' to access the device (5901 relates to address 1, 5902 to address 2, 5903 to address 3, etc., note the double colon).

Note: The IP address shown on the communications screen of the Touch Screen is the LAN address and would not typically be used for an Internet connection.

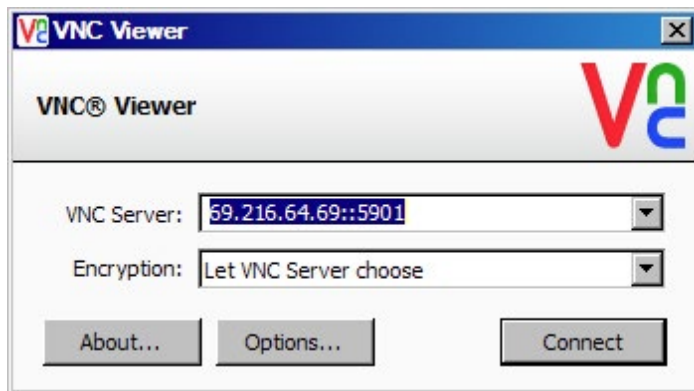

Fig. 135: VNC Viewer - Internet

- D. **Security Example:** If the VNC server password is enabled on the Touch Screen (for either example above) upon pressing the "Connect" button to make the connection, the VNC viewer will prompt for the proper password. The connection will only be established once the valid password is entered (Fig. 136).

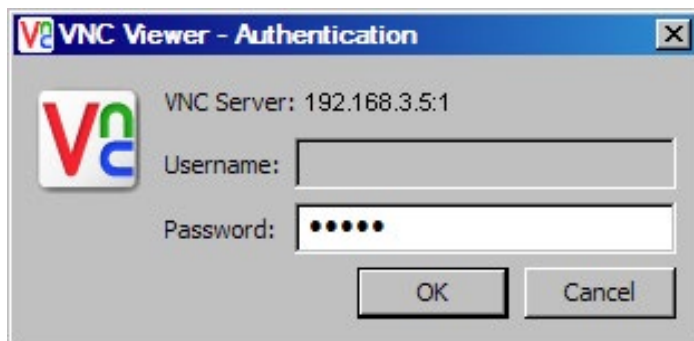

Fig. 136: VNC Viewer - Authentication

- E. Once the connection is established, the current Touch Screen display will be shown on your desktop (Fig. 137). The image will be a duplicate of what is on the Touch Screen. As you manipulate the screen, the display of Touch Screen will also be manipulated so that any local operator will be able to see what is happening and vice versa.

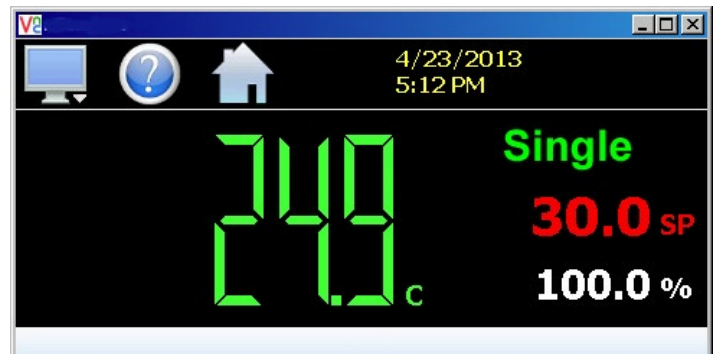

Fig. 137: Touch Screen Appearance on Desktop

Multiple Instances of VNC Viewer

Multiple instances of the VNC viewer can be started on your PC. By running multiple viewers, you can have access to multiple Touch Screen controllers right from your desktop. The heading of each VNC viewer window will use the 'VNC Device Name' entry for the header. By entering a unique name for each Touch Screen, you can identify each VNC connection and know which system you are accessing.

The VNC viewer is meant to be used for short-term control access to Touch Screen. It is not meant for long-term monitoring of system operation. If long-term monitoring access is desired, use the built-in web server of Touch Screen to monitor and control Touch Screen over its serial communications port. The web server interface and PC software is designed for long term monitoring and status updates.

Due to the nature of VNC operation, and for security reasons, the VNC viewer connection should not be left open on your desktop. The viewer connection should be opened in order to perform the necessary control and/or status check of system operation, and then closed once the task is complete. Accidental manipulation of the control or erroneous network activity could cause connection problems over the VNC interface and result in the VNC server shutting down and requiring Touch Screen to be restarted in order to regain access.

Note: Some viewers may also contain additional features for file transfer and other high level functions. These functions are NOT compatible with Touch Screen. Any attempt to use them may cause the Touch Screen VNC server to malfunction and require power to be cycled in order to reboot the system. All viewers should be used ONLY to monitor and manipulate the Touch Screen as if you were standing directly in front of it.

Serial Communications Option

The Touch Screen serial interface uses Modbus RTU protocol. Any device used to communicate with Touch Screen over the serial interface must use this protocol. The interface can be configured to operate in either standard Touch Screen LC mode or a simulated Watlow F4S/D mode (Fig. 138).



Fig. 138: Serial Comms Setting

When configured for the standard Touch Screen LC interface, the communication address and parity can be set on the Web/Modbus/VNC. All other communication settings are fixed. The port settings of the device used to communicate with Touch Screen must be set to match in order for the communications to take place.

Address: 1-31 (user selectable)

Baud Rate: 9600

Data Bits: 8

Stop Bits: 1

Parity: None, Odd, Even (user selectable)

When configured for the simulated Watlow F4S/D interface, only the communications address can be set. The parity setting is hidden and defaulted to "None" in order to be compatible with WatView software or other devices used to communicate with a Watlow F4S/D controller. The port settings of the device used to communicate with Touch Screen

must be set to match the standard F4 settings as follows:

Address: 1-31 (user selectable)

Baud Rate: 19200

Data Bits: 8

Stop Bits: 1

Parity: None

The Modbus address is used to identify Touch Screen on the serial link. When a multi-drop connection is used, each controller on the link must have a different address so that each one can be identified separately. If two or more Touch Screen controllers have duplicate addresses, communications with those controllers will fail because they will each try to respond to the same message. For single Touch Screen connections, the address only needs to match that of the commands being sent from the host device.

The F4S/D controller and WatView are registered trademarks of the Watlow Electric Manufacturing Company.

Installing the Shelves

1. Turn the warming cabinet power switch to OFF.
 - A. Allow the heating chamber to cool. Then unload any contents.
2. Install the four shelf support clips into the desired location by inserting the top tab into the upper wall slot of that position (Figs. 140 & 142). Push up slightly on the inserted top tab and push the bottom half of the clip in until the bottom tab snaps into the lower slot.
3. Count the mounting locations at each corner of the chamber to be sure that the shelf will be level and install the remaining support clips.
4. Install the shelf with the notches on the bottom of the shelf aligned with the shelf supports (Figs. 139 & 141).
5. Pull outward on the shelf to ensure it is locked properly on the supports.

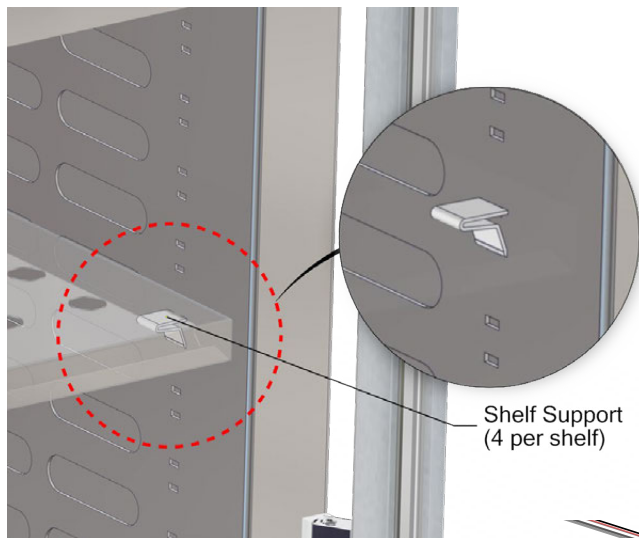

Fig. 139: Shelf Support

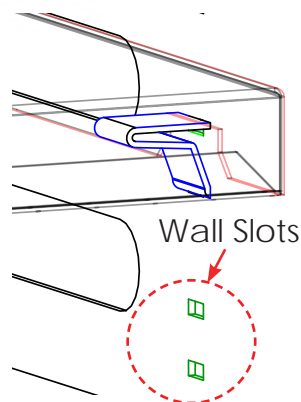

Fig. 141: Support Clip Fitted in Notch



Fig. 140: Shelf Support showing tabs

NOTE: Shelves are notched at each corner to rest on four shelf support clips that are inserted into the cabinet wall slots (Fig. 142).

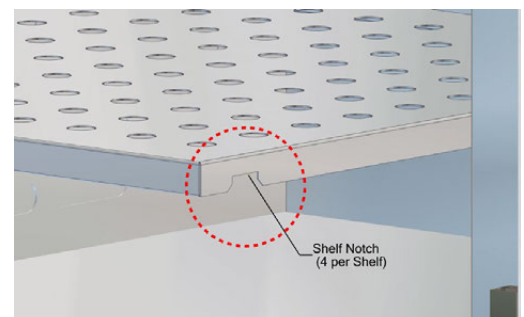

Fig. 142: Shelf Notch

Adjusting the Shelves

1. Turn the warming cabinet power switch OFF.
 - A. Allow the chamber to cool. Then unload the contents.
2. Remove the shelf and determine its new position.
3. Remove the four (per shelf) shelf supports clips by tilting the clip upward and lifting out.
4. Install the shelf support into the new location by inserting the top tab into the upper slot of the new position. Push up slightly on the inserted top tab and push the bottom half of the clip in until the bottom tab snaps into the lower slot.
5. Count the mounting locations at each corner of the chamber to be sure that the shelf will be level and install the remaining supports.
6. Reinstall the shelf with the notches on the bottom of the shelf aligned with the shelf supports.
7. Pull outward on the shelf to ensure it is locked properly on the supports.

Installing and Adjusting Optional Roller Basket Shelves

Install the roller basket shelf by first attaching the two roller channels to the cabinet walls.

1. First, insert the top tab of one end of the roller channel into a slot (the roller channel width spans four slots). (Figs. 143 & 144).
2. After inserting the top tab, push up slightly on it while snapping in the bottom tab into a slot located three slots below the top slot (Fig. 145).
3. Snap in the other end (make sure it is level with the first end) and attach the other roller channel to the opposite side in the same manner. Be sure both channels are level with each other.

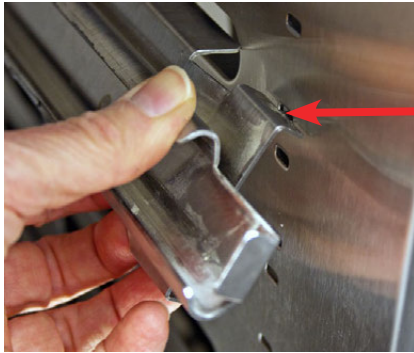

Fig. 143: Inserting Top Channel Tab

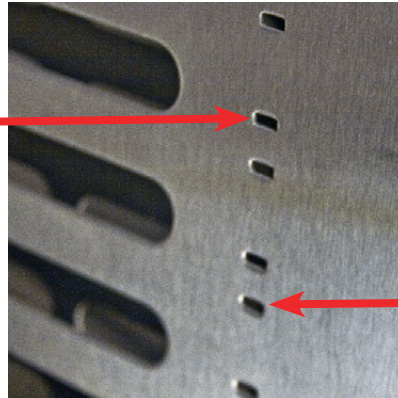

Fig. 144: Cabinet Wall Slots

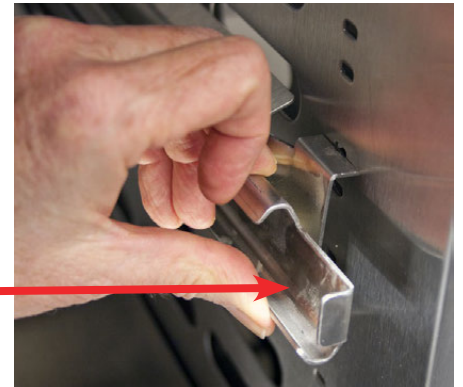

Fig. 145: Inserting Bottom Channel Tab

4. Set the two sets of rollers of the roller basket into the channel tracks on both sides and slide the shelf in (Fig. 146).



Fig. 146: Rollers in Channel Track

Adjust the Roller Basket Shelf

1. To adjust the roller basket shelf, slide the shelf out and lift up to clear the rollers from the roller channel track. Set the shelf aside.
2. Remove the roller channels by pushing up slightly on the top tab of the channel and pull out the channel from the bottom.
3. Reinstall the roller channels in another location using the same installation process described above.
4. After reinstalling the roller channels, reinstall the shelf by aligning its rollers in the roller channel track and sliding the shelf in.



Patient Safety – Maximum Warming Temperature Limit

Warning  **Injury or Burn Hazard:** DO NOT use heated liquids on, or inject in, living tissue unless actual liquid temperature has been measure and found acceptable. The temperature of the Warming Cabinet contents may be hotter than the displayed temperature. For patient safety (in accordance with optimal medical practice), always verify liquid temperature with a thermometer at the point of use.

Important: See Maximum Warming Temperature Limit for Patient Safety table below.

Maximum Warming Temperature Limit for Patient Safety (as recommended by ECRI)	
Items to be Warmed	Maximum Temperature Limit
Liquid Solutions for use on living tissue	110°F (43°C)
Blankets	130° (54°C)

Unloading the Warming Cabinet

Caution  **Injury and Burn Hazard:** Avoid injury by using proper personal protective equipment when loading or unloading the Warming Cabinet. Internal surfaces are hot, glass may shatter when cooled suddenly and solution bags or bottles may burst when picked up. Rotate warmed contents on a first-in, first-out basis. Failure to do so may present cold or discolored contents.

Turning off the Warming Cabinet

Switch the ON/OFF Switch to the OFF position.

Cleaning Stainless Steel Warming Cabinets

Stainless steel Warming Cabinets must be cleaned on a regular basis to prevent any unnecessary damage to the stainless steel surfaces. Spilled liquids and standing water should be cleaned up immediately.

When cleaning stainless steel Warming Cabinets, make sure to use the proper approved cleaning agents and cleaning materials to protect the surface and prevent damage or corrosion.

CAUTION: DO NOT USE these Cleaning Materials	CAUTION: DO NOT USE these Cleaning Agents
Abrasive Pads	Hard Water (water with a pH reading above 7.0)
Scrapers (metal or plastic)	Hydrochloric Acid
Steel Wool	Steam or high pressure water
Wire Brushes	Bleach or any compounds containing chlorine or Sodium hypochlorate, or ammonium chloride salts

Approved cleaning materials and agents		
Soft, clean lint-free cloth	Non-abrasive cleaning pads	Soft bristle brush
Mild detergents	Sodium Bicarbonate (baking soda)	Distilled water (pH rating 7) alone or with a mild detergent
White vinegar (in a spray bottle)	Isopropyl Alcohol	Hospital-grade non-bleach disinfectants
Cleaners approved for use on stainless steel		

Cleaning Stainless Steel Surfaces

- Using a damp, lint-free cloth and approved cleaner, wipe down the entire exterior surface of the stainless steel Warming Cabinet. Using a damp, lint-free cloth with distilled water and a mild detergent, wipe down the entire exterior surface of the stainless steel cabinet.
- Clean the Warming Cabinet with the stainless steel surface grain as shown here.



- Let cleaned Warming Cabinet air dry.

Cleaning Decals or Printed Labels

- Use only distilled water and a mild detergent applied with a clean, dry lint-free cloth to clean decals or printed labels.
- Cleaning agents can remove or smear any printing from decals and print labels.
- Cleaning agents can damage plastic materials used in manufacturing covers for electronic items such as touch-screen pads.

Disinfecting Stainless Steel

- Use a hospital grade non-bleach disinfectant. Always follow the manufacturer's instruction for proper use of these products.

Cleaning the Warming Cabinet Interior:

- Unplug and remove the Warming Cabinet from its power supply.
- CAUTION:** Turn OFF Circuit Breaker if Warming Cabinet is hard wired into the facility's electrical supply.
- Open the door and remove all adjustable shelves and shelf clips.
- Clean the adjustable shelves and shelf clips separately.
- Using a damp, lint-free cloth and approved cleaner, wipe down the interior of the cabinet.
- Use a lint-free dry cloth to dry the cabinet's interior or let air dry. If air drying, ALWAYS leave the cabinet door open.

Cleaning Glass Doors (if applicable):

Use a commercially prepared ammonia-free glass cleaner or use distilled water and a mild detergent applied with a lint-free cloth.

Preventative Maintenance Checklist

Operator Maintenance

Users are responsible for the thorough inspection of the equipment before and after each use. Should any problems or deficiencies arise, the results must be reported to the facilities maintenance personnel. The safety of personnel and patients relies on the proper and routine maintenance of this equipment.

Daily Checklist

1. Ensure that the correct operation and maintenance manual is available to all users.
2. Ensure that all personnel using this appliance have been properly trained in the warmer cabinet operation and safety instructions.
3. DO NOT overload cabinet. Load contents (blankets or fluids) into the chamber with a minimum of 1 inch of space between walls and fan to allow for circulation (as seen below).

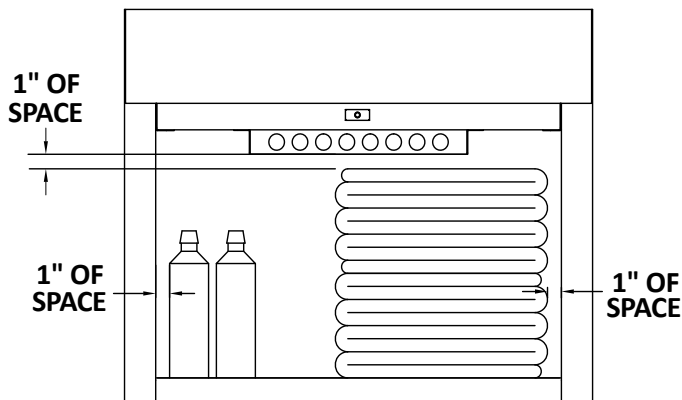

Weekly Checklist

1. Inspect condition of plug and cord. Replace if damaged.
2. Clean dust from back and side vents.
3. If any of the chamber shelves are unstable when setting objects on them, check the shelf clips that the shelves sit upon. Make sure these are not loose. If any are loose, snap back into place.
4. Check basket shelves (if applicable) and side rail condition. Do the baskets move smoothly and freely?
5. Check that all control indicators (heat and alarm) and Touch Screen display light up. At power up, the Touch Screen Display panel must display HOME, HELP, MONITOR icons, date/time, current temp, name of chamber, temp set point, percentage of output. The current temp will match the set point as it heats to its set point. The percentage of output should decrease as the warmer cabinet reaches and its set point temp.



6. Periodically check the alarm by setting the temperature $\pm 10^\circ$ from set point to test the alarm. If the temperature rises or drops 10 degrees below its set point, the alarm should buzz and its light goes on. (Note: 90°F is the lowest temperature point. To test alarm from this point, heat the unit up 10 degrees beyond its lowest temperature, then bring the set point down to test the alarm.)

Monthly Checklist

1. Check condition of casters or feet. Ensure components are secure and tightly threaded.
2. Check control panel overlay condition. Are there any tears or excessive wear on the graphic? Does the control work properly when buttons are pushed?
3. Is the set temperature comparable to the actual temperature displayed? Check chamber air temperature with a quality thermocouple placed 1 inch (25 mm) from the chamber. Do not allow the sensor to touch any surface. Monitor for approximately one hour in an empty chamber.

Semi-Annual Checklist

1. Check the temperature accuracy on a semi-annual basis by placing an IR Temp probe or thermocouple on calibrated meter near the fan inlet. In general, air temperature should be $\pm 1^\circ\text{F}$ for upper chamber and counter top units and $\pm 3^\circ\text{F}$ for lower chambers and large single cabinet units. See table column "Temperature Tolerance" on page 22 for details. If the cabinet is not within these guidelines, contact MAC Medical for further assistance.
2. Check the Fan Blades for buildup of lint or other debris and clean as necessary. **NOTE:** MAC Medical recommends replacing the Fan Motor with Fan Blade (Part # - W0036 (120V)/ W0106 (220V)) every two years to ensure uninterrupted service.

Replacement Parts – General

TS-Series Warming Cabinet replacement parts listed on this page have been identified by MAC Medical as serviceable by facility personnel and are available for purchase. To obtain MAC Medical certified parts and authorized services, contact your MAC Medical representative.

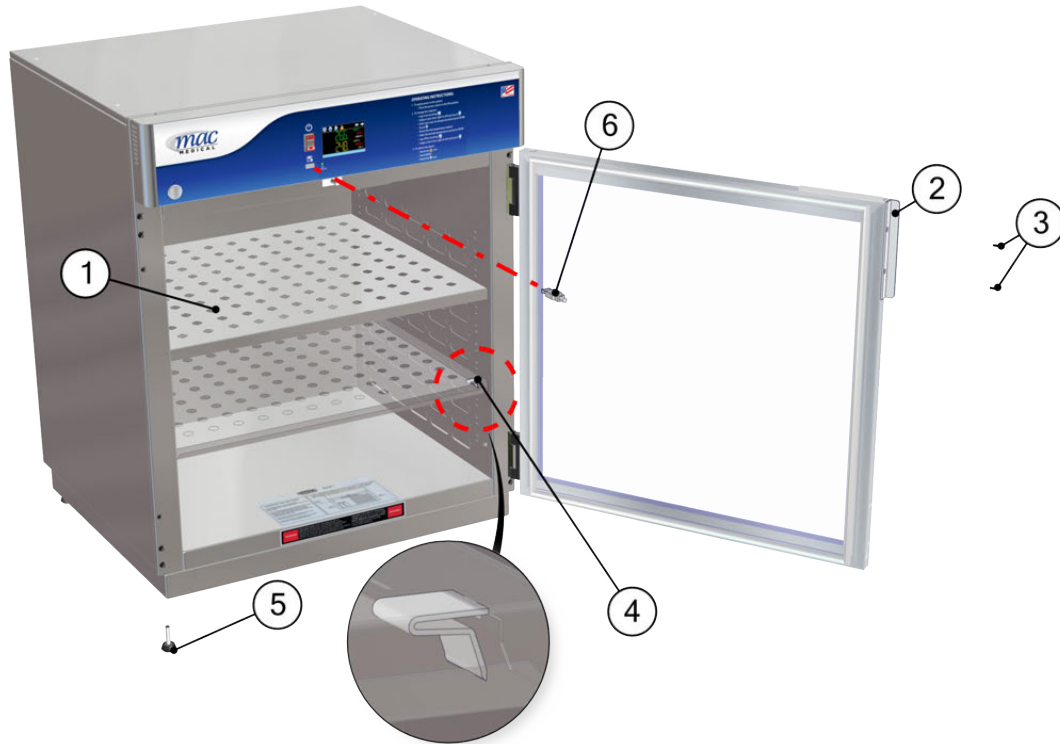

Fig. 147: TS Series Cabinet Replacement Parts

Item	Part #	Description	QTY
1	SWW0055	Adjustable Shelf	As Required
2	W0050	Handle, Stainless Steel Door, LH Upper, RH Lower (Dual/Triple Upper Chamber)	1
	W0051	Handle, Stainless Steel Door, LH Lower, RH Upper (Dual Lower Chamber, Triple Middle Chamber)	1
	W0052	Handle, Stainless Steel Door Single Chamber & Triple Lower Chamber	1
	W0053	Handle, Glass Door	1
3	H0006-1	8-32 X 1/2" Undercut Flat Head Screw (used with W0050, W0052, W0052)	3 per handle
	H0008-1	8-32 X 1/2" Screw (used with W0053)	2 per handle
4	W0043	Clip, Shelf	4 per shelf
5	W0135	Leg Leveler	4
6	W0600-S	USB Drive, Data Retrieval (1 per chamber)	As Required

Replacement Parts – Header Assembly and Electrical Drawer

The Parts identified in this section require an authorized MAC Medical service technician.

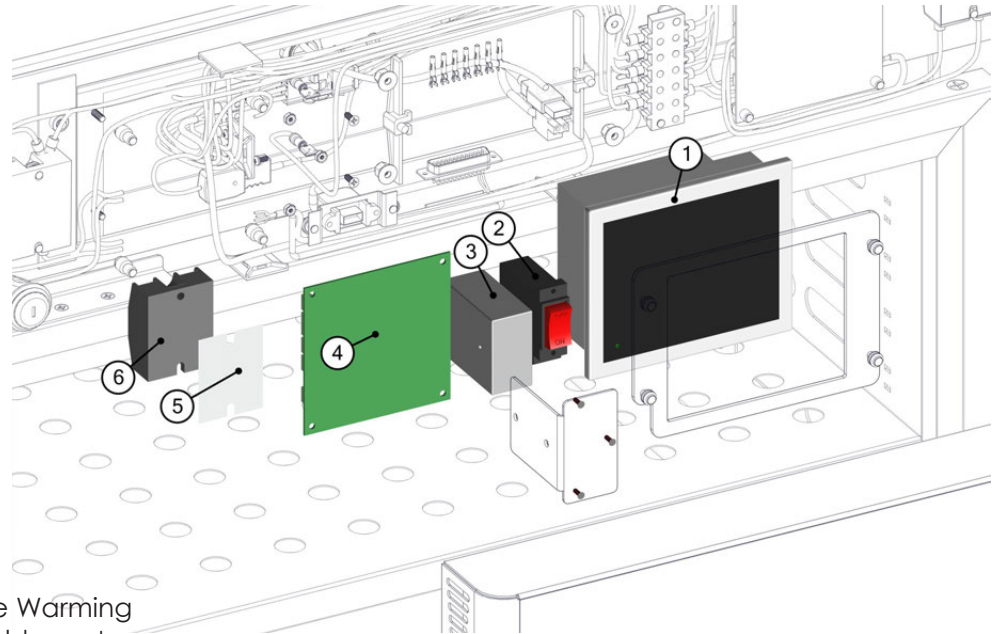

Fig. 148: Header Assy Replacement Parts

⚠ Injury Hazard: The design of the Warming Cabinet allows limited user serviceable parts or procedures. For optimal usage, safety and durability of the product, service must be performed by a MAC Medical authorized service technicians using MAC Medical authorized replacement parts and service techniques.

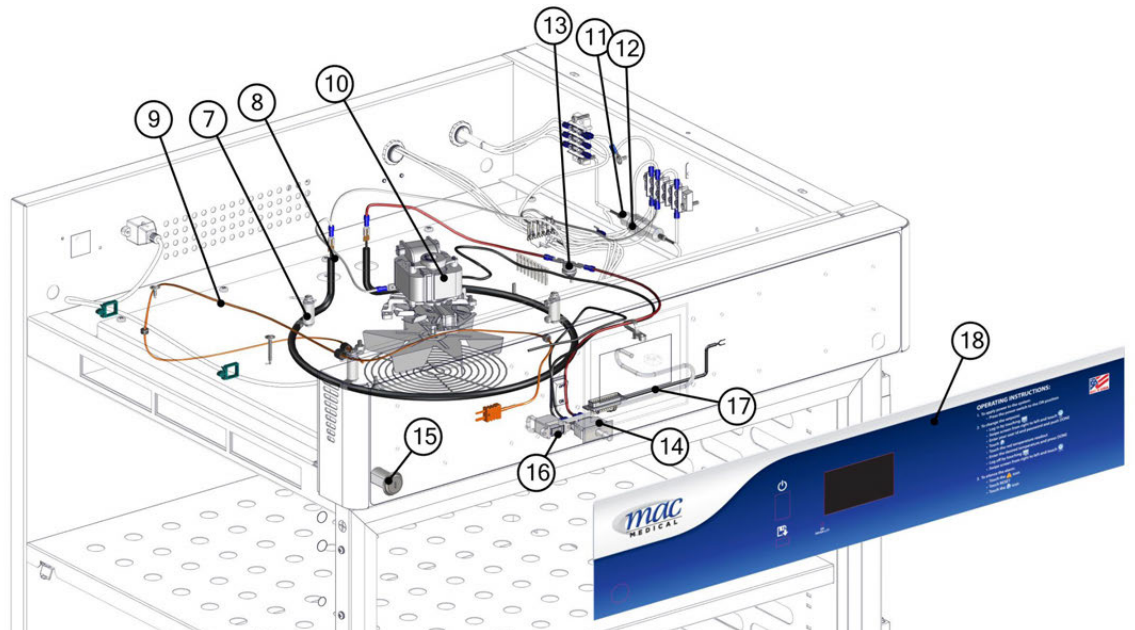

Fig. 149: Electrical Drawer Replacement Parts

Table 1

Item #	Part #	Header Assembly and Electrical Drawer Parts Description
1	W1001-01	Touch Screen Display
2	W0011-01	Power Switch
3	W1002-02	Touch Screen Display Power Supply
4	W1000-01 W1000-02	Touch Screen Controller (Upper)- Single Touch Screen Controller (Lower)
5	W0137	Heat Sink Pad
6	W0083	Solid State Relay
7	W0010	Ceramics
8	See table 2	Heating Element
9	W0037	Thermocouple
10	W0036 W0106	Fan Motor with Fan Blade (120V) Fan Motor with Fan Blade (220V)
11	W0110-02	Fuse Holder
12	See Table 3	Fuses
13	W0042	Over-Temp Thermocouple
14	W0012 W0012-01	Door Switch Door Switch w/long stem (bottom glass doors on dual chamber units, all stainless steel doors)
15	H0141	Door Lock
16	W0525-04	USB Plug and 10" Data Cable
17	W1003-01	Cable
18	W0334S-MAC	Overlay 30"

Table 2 (Heating Element - Item 8)

Part #	Size	Volt/Watt	Where Used
W0069	9"	110V/350W	SWC182424-TS, SWC243024-TS, DWC182464-TS, DWC183064T-TS, DWC243024-TS, DWC243074T-TS,
W0069-220	9"	220V/350W	SWC182424-220-TS, DWC182464T-220--TS
W0069-01	9"	110V/750W	SWC183064-TS, SWC183074-TS, SWC243074-TS, SWC182464-TS, DWC182474E-TS, DWC242474E-TS, DWC242474T-TS
W0069-01-220	9"	220V/750W	SWC183064-220-TS, SWC183074-220-TS, SWC243074-220-TS, SWC182464-220-TS, DWC242474T-220-TS
W0302	9"	110V/650W	SWC243036-TS, SWC182424-TS, SWC182436-TS, SWC182472-TS, SWC183036-TS, SWC242424-TS, SWC242436-TS, SWC242464-TS, SWC243064-TS, DWC183074E-TS, DWC183064T-TS, DWC183074T-TS, DWC182464T-TS, DWC182474E-TS, DWC182474T-TS, DWC242474E-TS, DWC243074T-TS
W302-220	9"	220V/650W	SWC183036-220-TS, SWC243036-220-TS, DWC183074E-220-TS, DWC182474T-220-TS, DWC183064T-220-TS, DWC243074T-220-TS, DWC182464T-220-TS
W0003	12"	110V/750W	SWC243024-TS, SWC243036-TS, SWC243074-TS, DWC243024-TS, DWC243064T-TS, DWC243074E-TS
W0107	12"	220V/750W	SWC182424-TS, SWC182464-TS, SWC183024-TS, SWC242474-TS, SWC243024-TS, SWC243074-TS, DWC182464T-TS, DWC183064T-TS, DW242474T-TS, DWC242464T, DWC243074T-TS

Table 3 (Fuses - Item 12)

Part #	Description	Where Used
W0395	Fuse 7A (use 2)	For all single chamber 220V cabinets
W0396	Fuse 10A (use 2)	For all dual chamber 220V cabinets
W0124	Fuse 15A	For all 110V single chamber cabinets
W0125	Fuse 20A	For all 110V dual chamber cabinets

Optional Cabinet Bases, Mobile Bases and Mobile Stands

All warming cabinets are shipped with a standard 4" base unless otherwise specified. The table on the right lists the base part number and sizes for various sized cabinets.

The two tables below list the mobile bases/stand part numbers for the single, dual and triple cabinets.



SWM0307-02 shown here

Part #	Base
SMW0307-02	4" base for 18 x 24 cabinets
SMW0359-02-WM	2" base for 18 x 24 cabinets
SMW0359-03-WM	6" base for 18 x 24 cabinets
SMW0062-02	4" base for 18 x 30 cabinets
SMW0047-08	2" base for 18 x 30 cabinets
SMW0062-03	6" base for 18 x 30 cabinets
SMW0308-01	4" base for 24 x 24 cabinets
SMW0308-05	2" base for 24 x 24 cabinets
SMW0308-04	6" base for 24 x 24 cabinets
SMW0047-03	4" base for 24 x 30 cabinets
SMW0047-10	2" base for 24 x 30 cabinets
SMW0047-09	6" base for 24 x 30 cabinets

Single Cabinet Model #	Mobile Base/ Stand Part #	Overall Dimensions
SWC182464-TS, SWC182474-TS	MB1824	27"W X 22"D X 6.85"H
SWC182424-TS, SWC182436-TS, SWC182464-TS	MS1824	28"W X 20"D X 34.125"H
SWC183064-TS, SWC183074-TS	MB1830	33"W X 22"D X 6.73"H
SWC183024-TS, SWC183036-TS	MS1830	34"W X 20"D X 35.81"H
SWC242424-TS, SWC242464-TS, SWC242474-TS	MB2424	27"W x 28"D x 6.75"H
SWC242424-TS, SWC242436-TS	MS2424	26"W x 26"D x 34"H
SWC243064-TS, SWC243074-TS	MB2430	33"W x 28"D x 6.75"H
SWC243024-TS, SWC243036-TS	MS2430	34"W X 26"D X 34"H



MS1824



MS1830 & MS2430



MS2424

Dual Cabinet Model #	Mobile Base Part #	Overall Dimensions
DWC182464T-TS, DWC182474E-TS, DWC182474T-TS	MB1824	27"W X 22"D X 6.85"H
DWC183064T-TS, DWC183074T-TS, DWC183074E-TS	MB1830	33"W X 22"D X 6.73"H
DWC242464T-TS, DWC242474E-TS, DWC242474T-TS	MB2424	27"W X 28"D X 6.75"H
DWC243064T-TS, DWC243074T-TS, DWC243074E-TS	MB2430	33"W X 28"D X 6.73"H

Shelf Basket Part #	Warming Cabinet Model #	Basket Overall Dimensions
WB1824	SWC182424-TS, SWC182436-TS, SWC182464-TS, SWC182474T-TS, DWC182464T-TS, DWC182474E-TS, DWC182474T-TS,	16.92"W x 16"D x 5"H
WB1830	SWC183024-TS, SWC183036-TS, SWC183064-TS, SWC183074-TS, DWC183064T-TS, DWC183074T-TS, DWC183074E-TS,	22.98"W x 15.88"D x 5"H
WB2424	SWC242424, SWC242436-TS, SWC242464, SWC242474, DWC242464T, DWC242474E-TS, DWC242474T-TS	16.98"W x 21.75"D x 5"H
WB2430	SWC243024-TS, SWC243064-TS, SWC243074-TS, DWC243036-TS, DWC243064T-TS, DWC243074T-TS, DWC243074E-TS,	23.10"W x 21.75"D x 5"H

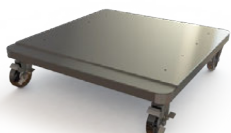

MB1830, MB2424, MB2430



WB1824, WB1830, WB2424, WB2430

Steel or Glass Door Hinge Reversal

! Before the Door Hinges can be reversed, the top and side panels of the cabinet must be removed, and the Cam Lock must be relocated.

Remove Top Panels

The Following steps for panel removal apply to cabinets with either steel or glass doors. For cabinets that have been set into a wall enclosure, the cabinet must be pulled out to allow free access to various cabinet parts.

1. For both glass and stainless steel doors, remove the outside top panel by unscrewing the four top panel screws and lifting the panel out. Remove the inside top panel by unscrewing the two screws and lifting the panel out (Fig. 150).



Fig. 150: Remove Top Panels

2. Remove the two screws located inside the cabinet (one on each side) near the bottom. (Figs. 151 and 152. Door removed for clarity in these illustrations.)

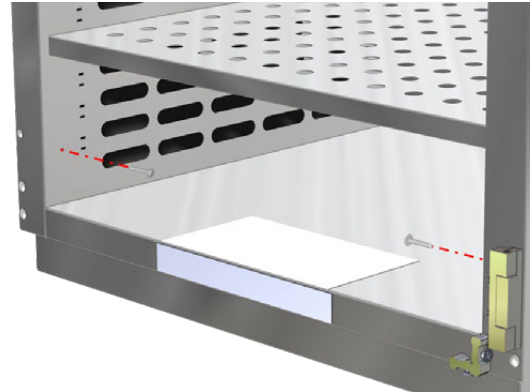

Fig. 151: Remove Interior Cabinet Screws - Glass Door Unit



Fig. 152: Remove Interior Cabinet Screws - Steel Door Unit

3. Remove the screws at the back of the cabinet and slide out both side panels (Fig. 153).

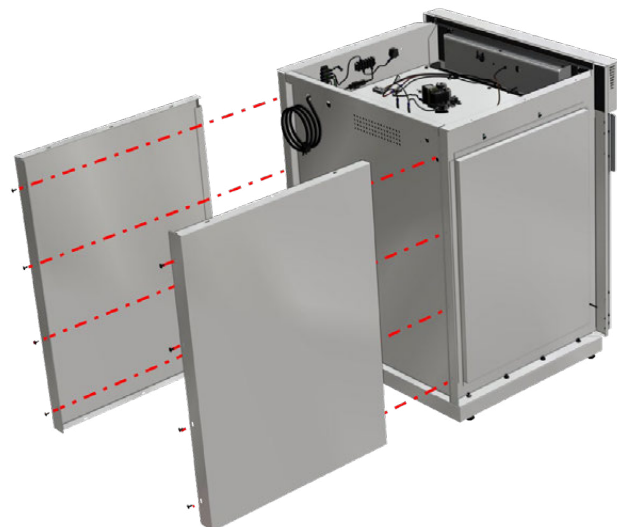

Fig. 153: Remove Side Panels

Remove Header Assembly Box & Relocate Cam Lock

Purchase Parts Needed for Cam Lock Reversal

- Felt Strip (Part #ST0014)
- Plug (Part #W0098)

The following steps apply to cabinets with steel or glass doors. Cabinets are equipped with a cam lock in the header assembly. This must be moved to the other side of the header assembly box when the door hinges are reversed. The door itself has a cam lock plate that also must be moved near the new location of the cam lock. (Note: Only top doors on multi-chambered have a cam lock plate.)

4. To remove the Header Assembly Box, unscrew four hex locking bolts from the header assembly box mounting plates, unplug the 9 pole wire connector, ethernet connection and thermocouple plug (two plugs if a dual cabinet). Then remove the header assembly box (Fig. 154).

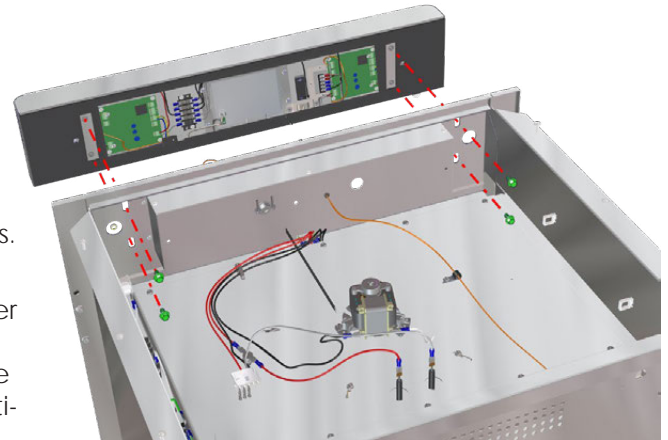

Fig. 154: Remove Header Assy Box



Fig. 155: Cut Out Rectangular Sections from Gasket

5. To access the cam lock and its new location, peel back the gasket cover in the location shown by the red rectangles (Fig. 155).

Figure 156 shows the header assembly interior (gasket removed for clarity). The cam lock (in red rectangle) will be moved to the two oblong knock-out areas circled in red and highlighted in blue (see detail Fig. 157).

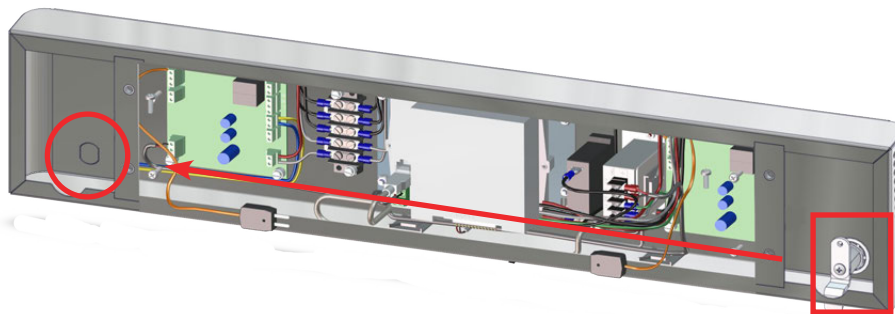

Fig. 156: Cam Lock to be Moved to New Location

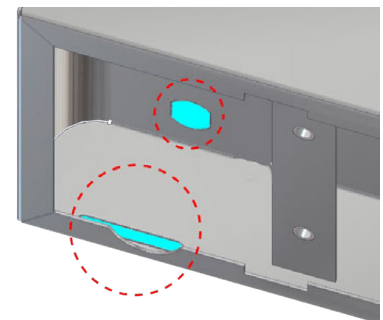

Fig. 157: Knock Out Areas

- At the new cam lock location, remove the two oblong knock-out areas. Cut an oblong shape in the plastic overlay covering the short-wide oblong knock-out area to accommodate the cam lock when it is re-installed (Figs. 158 & 159). The narrow-long oblong knock-out area will be the slot the cam lock latch fits in.

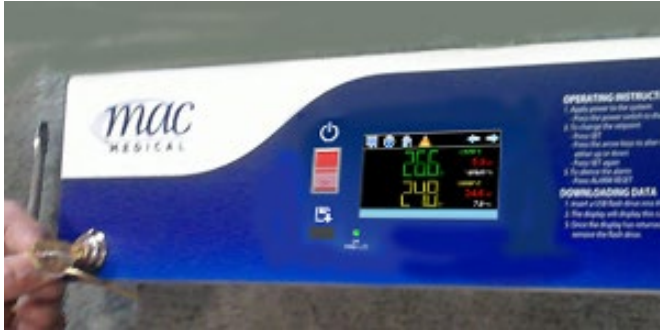

Fig. 158: Overlay - Cam Lock Location - Right Hinged Door



Fig. 159: Overlay-Cam Lock Location - Left Hinged Door

- To detach the Cam Lock assembly, unscrew the Phillips head screw from the Cam Lock Latch (Fig. 160).
- Unscrew the Hex Nut and remove the Trim Ring.
- Pull the Cam Lock body out from the face of the Header Assembly.
- Insert purchased Plug (W0098) into the hole originally occupied by the lock.
- To reinstall at the new position, slide the Trim ring onto the barrel of the Cam lock insert Cam Lock body through the oblong hole at the new position in the face of the header (Fig. 161).

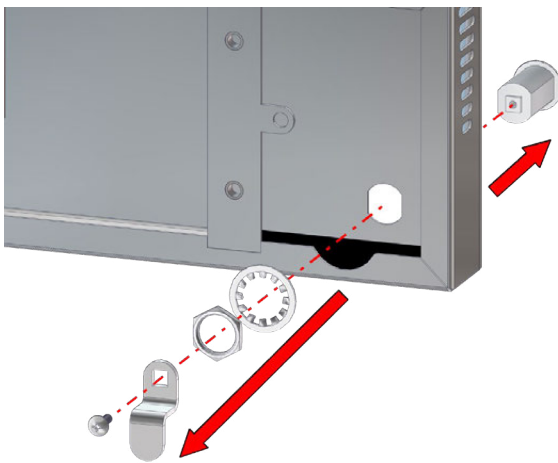

Fig. 160: Detach Cam Lock Assembly

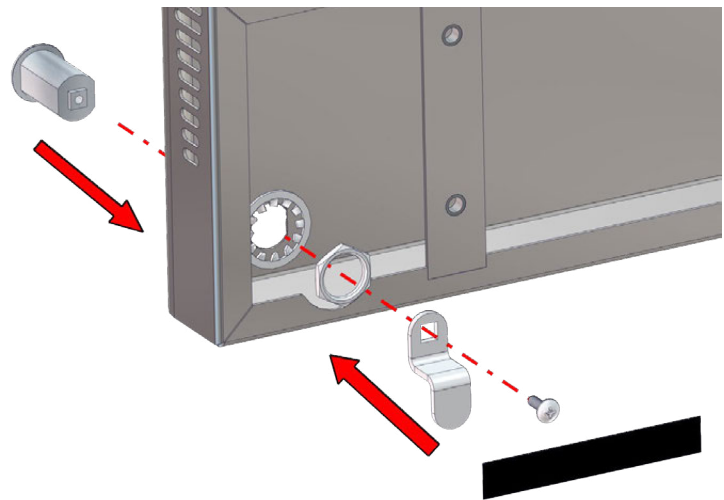

Fig. 161: Re-assemble and re-install Cam Lock



12. Secure the Cam Lock body to the header by attaching the Lock Washer, then the Hex Nut.
13. Affix the Cam Lock Latch to the Cam Lock body and secure it with a 8-32 Phillips head screw.
14. Insert the purchased Felt Adhesive Strip (ST0014) between the Cam Lock Latch and the header. Position it to keep the cam lock latch from falling down when the key is in the lock. When activating the lock, the latch will rub the felt strip (Fig. 163).
15. Use a piece of Felt Adhesive Strip to cover up the old oblong hole where the cam lock latch passed through the bottom of the header
16. Reinstall the Header Assembly and secure to the cabinet with its four screws.

Fig. 162: Assembled Cam Lock



Fig. 163: Assembled Cam Lock with Felt Adhesive Strip

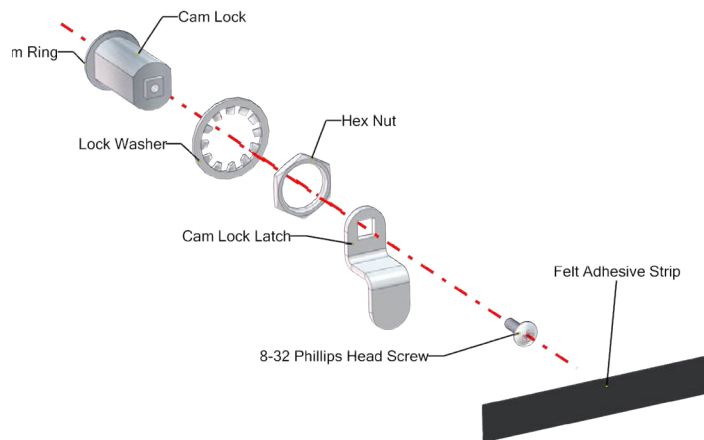

Fig. 164: Cam Lock Assembly Parts

Glass Door Hinge Reversal and Reinstallation

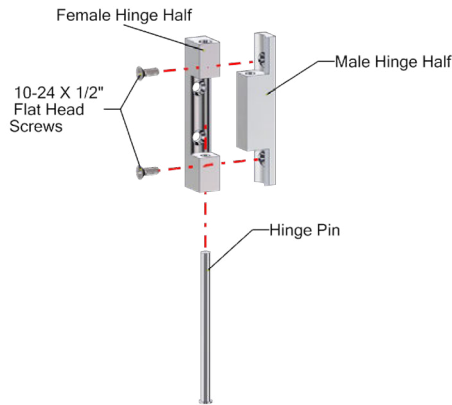

Fig. 165: Glass Door Hinge Parts

1. Using a drift pin (or a small headed screwdriver) and a hammer, detach the glass door from the unit by tapping lightly on the hinge pins, driving them through the two halves of the hinges. Then pull the door away from the unit to remove it (Fig. 166).
2. Detach the male halves of the glass door hinge by unscrewing them from the warming cabinet. The hinge halves on the door should remain in place (Fig. 167).
3. Unscrew the Door Handle and Cam Lock Plate from their present position and move them to the other side of the door. Make sure to "mirror" the Cam Lock Plate so that its top flange will be flush against the warming cabinet when the door is reinstalled in its new position (Fig. 168).

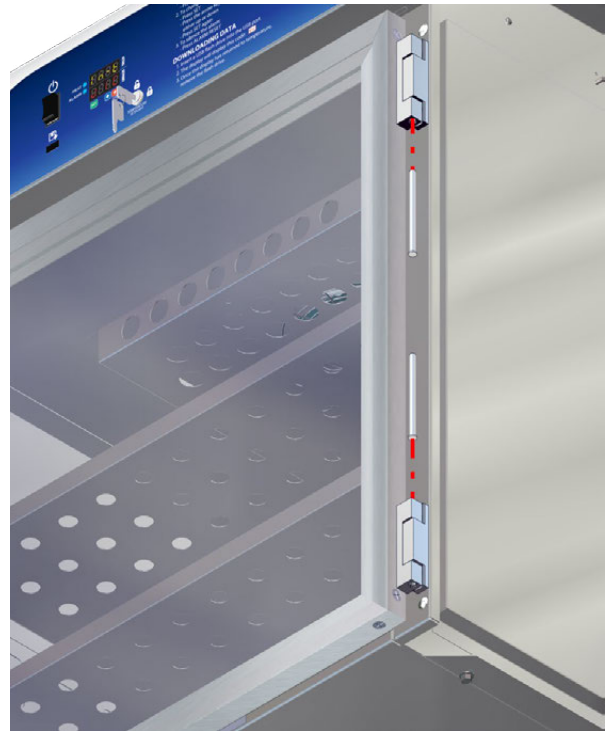

Fig. 166: Remove Door Hinge Pins



Fig. 167: Detach Glass Door Hinge - Male Half

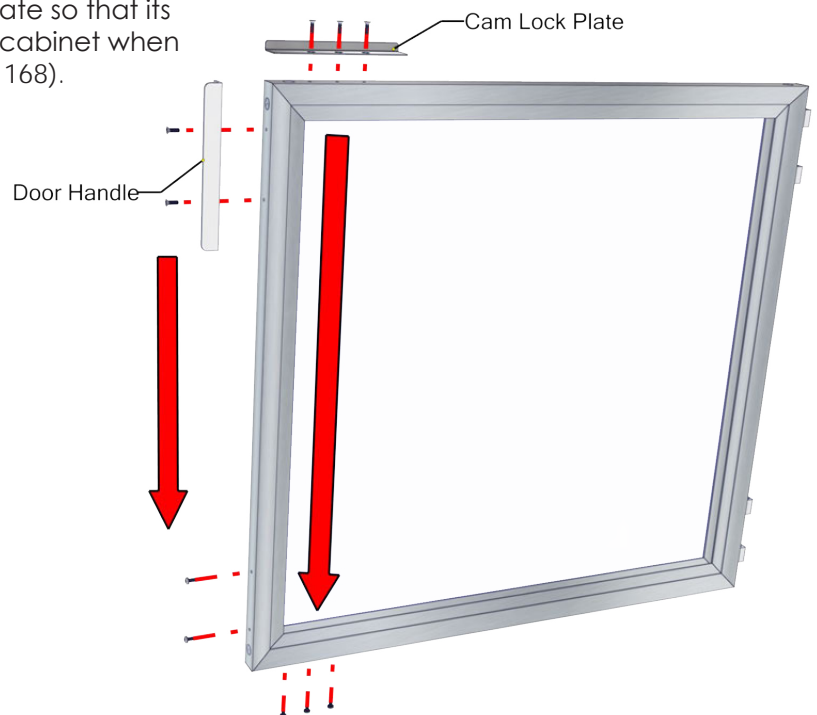

Fig. 168: Move Door Handle and Cam Lock Plate

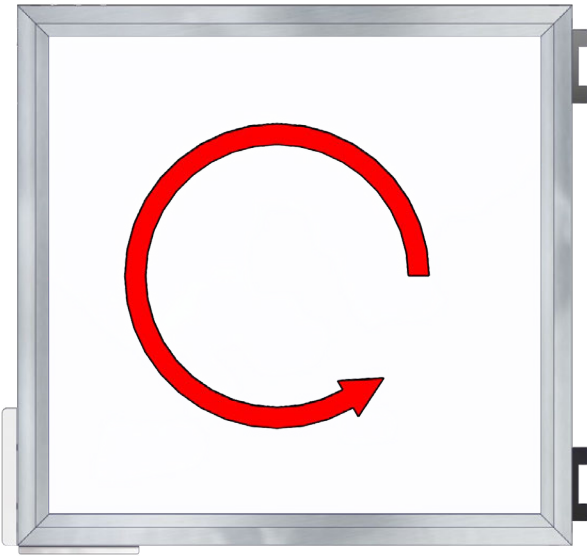

Fig. 169: Rotate Modified Door

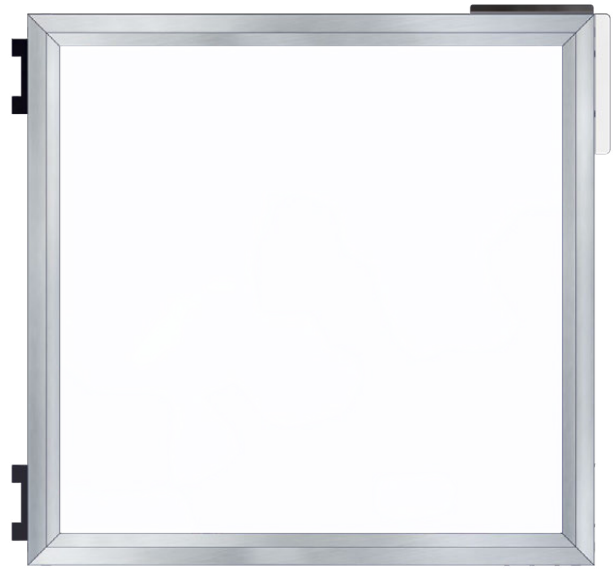

Fig. 170: Door Rotated to New Installation Position

4. With the door handle and the cam lock plate in their new positions, rotate the door 180° (Fig. 169). Figure 170 shows its orientation when reinstalling the door on its new hinge position.
5. Use a flathead screwdriver to remove the two smaller satin plugs (circled in red) from the top and bottom of the opposite side of the cabinet. These are the new hinge positions (Fig. 171).
6. Reinsert the two satin plugs (that were removed from the new hinge positions) in the old hinge positions.



Fig. 171: Remove Satin Plug from New Hinge Position

7. Re-install the male halves of the door hinges in these positions. Do not tighten the screws at this point (Fig. 172).
8. Attach the glass door to the unit by fitting the two halves of the glass door hinges together. Before securing the door to its hinges, square the door by checking the door's alignment with the header assembly box. Then tighten the hinge screws (Fig. 173).



Fig. 172: Install Male Hinge Halves in New Position



Fig. 173: Check Alignment - Square Door

9. To secure the door to its hinges, drive the hinge pins through the two halves of the hinges. Both pins should be driven into the hinges from the inside to the outside as shown in Figure 174.
10. Reattach and secure the side panels to the warming cabinet with its screws.
11. Reinsert the two interior cabinet screws near the bottom of the cabinet chamber.
12. Reinstall the inner and outer top panels and secure with its screws.



Fig. 174: Insert Hinge Pins

Steel Door Hinge Reversal and Reinstallation

Purchase Parts Needed for Door Hinge Reversal

- Intermediate Hinge (for multiple door units only) W0015 (Right Hand) or W0016 (Left Hand). Obtain the intermediate hinge opposite of the currently installed hinge.
1. Loosen the nuts on the bolts that hold the top door hinge onto the unit (Fig. 177). Hold the door as you remove the nuts so the door does not fall on you. Once the nuts are removed, the door can be leaned away from the unit and lifted off the bottom hinge (Fig. 175).

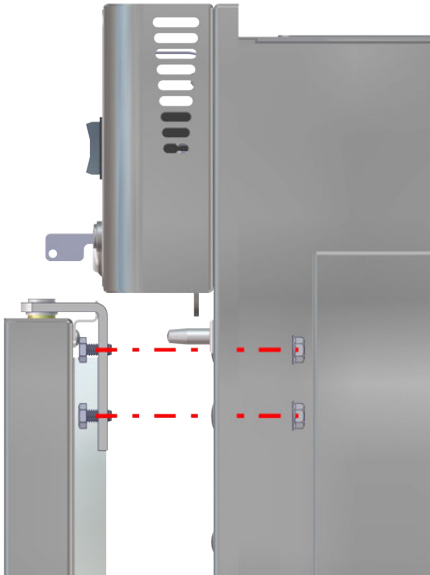

Fig. 175: Remove Steel Door

2. Remove the nuts that fasten the bottom hinge to the unit and remove the screws and bottom hinge (Fig. 176).

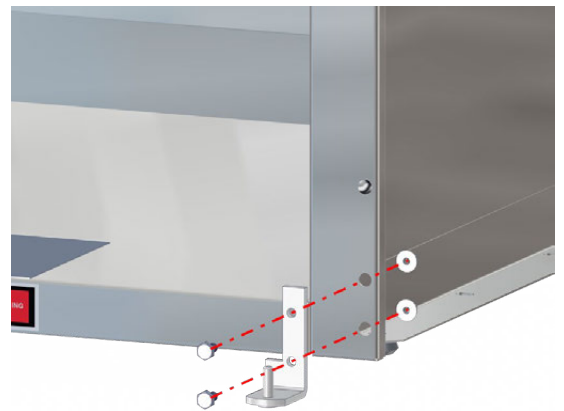

Fig. 176: Remove Bottom Hinge

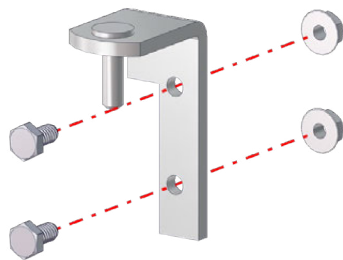

Fig. 177: Steel Door Hinge Parts

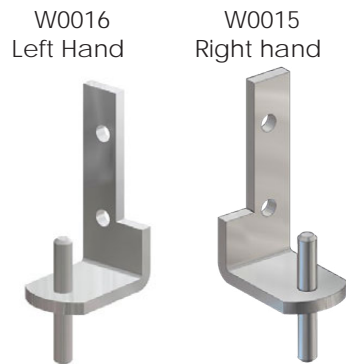

Fig. 178: Intermediate Door Hinge

Note: For warming cabinets with more than one door, an intermediate hinge (Fig. 178) fits between the bottom of the top door and the top of the bottom door of the dual chambered warming cabinet (shown in blue in Fig. 179). (Middle doors on Triple chamber warming cabinets use only intermediate hinges for both top and bottom.)

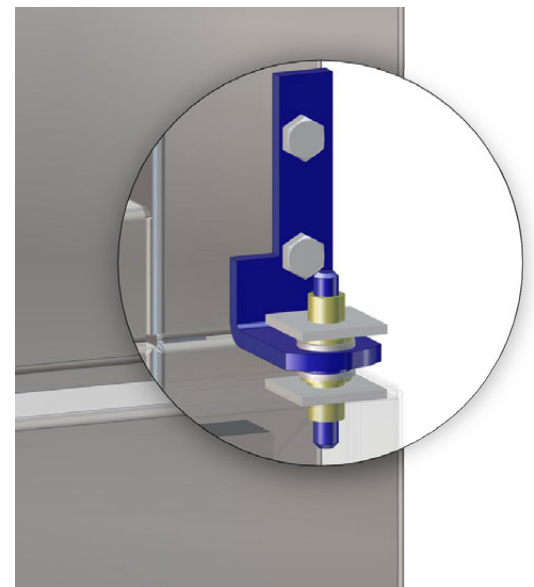

Fig. 179: Intermediate Door Hinge in Place

Intermediate hinges come as either right hand (part #W0015) or left hand (part #W0016) hinges. Purchase the intermediate hinge that is the opposite of the current one on your warming cabinet.

If the units has multiple doors, remove the intermediate hinges by unscrewing them from the cabinet.

3. After the door is removed, unscrew the Door Handle and Cam Lock Plate from their present position and move them to the bottom of the door. Be sure to “mirror” the Cam Lock Plate so that its top flange will be flush against the warming cabinet when the door is reinstalled in its new position (Fig. 180).
4. With the door handle and the cam lock plate transferred to their new positions, rotate the door 180°. This will be its orientation when reinstalling the door on its new hinge position.

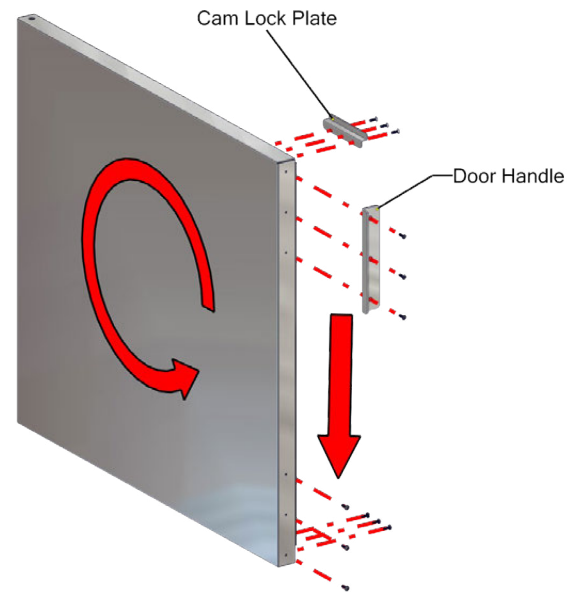

Fig. 180: Move Door Handle and Cam Lock Plate



Fig. 181: Remove Satin Plugs

5. From the opposite side of the cabinet, use a flathead screwdriver to remove the two top satin plugs (Fig. 181) from the top and the two lowest bottom satin plugs. These are the new hinge positions.
6. Reinsert the two satin plugs (that were removed from the new hinge positions) in the old hinge positions.

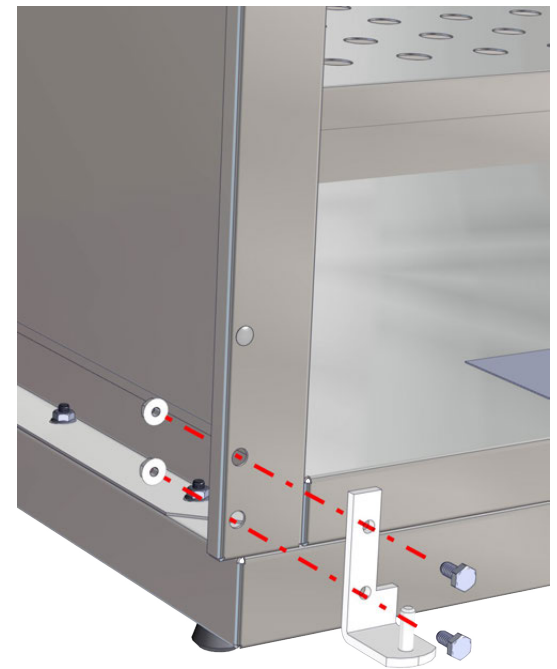

Fig. 182: Install Bottom Hinge in New Position

7. Attach the bottom hinge in the new position to the bottom of the unit using the hardware provided (Fig. 182).



Fig. 183: Door Hinge Socket

8. Look at the socket located on both the top and bottom of the door (circled in red in Fig. 183). The pins of the door hinges will insert into these. Fit the bottom socket of the door onto the bottom hinge pin. Support the door on its bottom hinge while you prepare to affix the door to the top hinge.
9. Insert the screws into the top hinge (or intermediate hinge, if applicable). Then insert the hinge pin into the top socket of the door, aligning the hinge screws with the top (or intermediate) hinge holes on the unit as shown in Figure 184.

10. From the side of the unit, secure the door and top hinge with the hinge nuts shown circled in red in Figure 184.

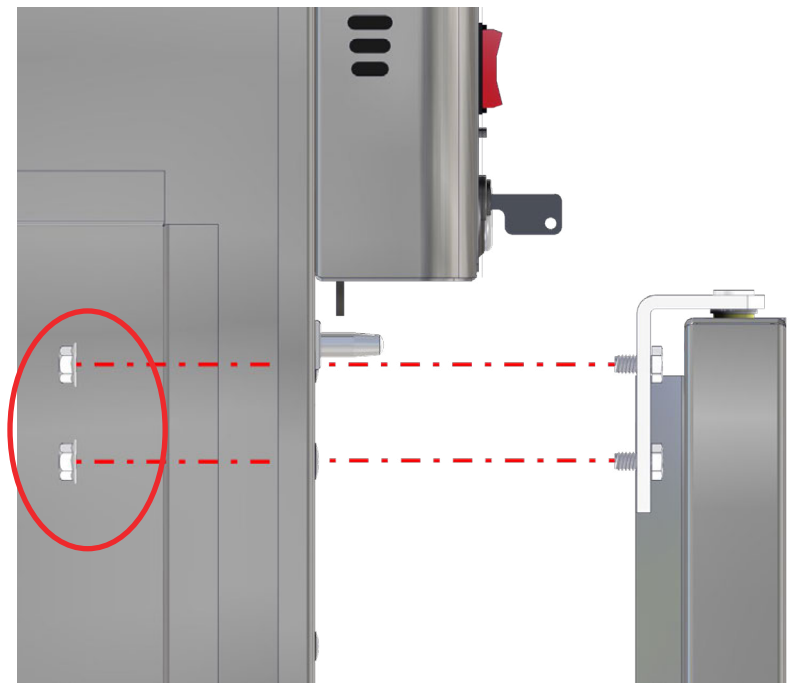

Fig. 184: Install Top Hinge and Secure Door

11. Square the door by checking its alignment with the header (Figure 185 shows a glass door, but the same applies for the steel door). Then tighten the hinge nuts.
12. Reattach both side cabinet panels with its screws.
13. Reinsert the two interior cabinet screws near the bottom of the cabinet chamber.
14. Reattach the inner and outer top cabinet plates.



Fig. 185: Check Alignment - Square Door

Appendix A - System Security User Access List

User right	Menu Location	Description
Set Point Edit	View/Single, Dual loop views	Applies to loop controls when not running an automatic ramp/soak program (does not apply to loop alarms)
Events	View/Events	Applies to enable or disable manual events
Manual Mode	View/Single	Enable or disable loop control Manual mode button
Automatic Tune	View/Single	Enable or disable loop control Automatic tune button
Program Operate	Program/Run, Hold, Stop actions	Applies to all program controls menu selections; does not affect digital inputs configured for same action
Recovery	Device/Settings/Offline/Set/Recovery	Logic when running an automated ramp/soak program when power lost and recovery
Reset Alarms	View/Alarm	Alarm Reset button
Clear Alarms	View/Alarm; Clear button	Prevents alarm list view from being cleared
Chart Settings	View/Chart	Configure plot channels, scale and time for charts
Data	Data/Data	Applies to all data logging actions and settings
Annotation	Data/View/Annotation	Access to add operator messages to active log file
Signature	Data/View/Signature	Access to add digital signature to active historical data file
Open	See description	Alarm, automatic program, audit and data files
Save	See description	Program "save" and "save as"; note files may be copied from system with USB file transfer utilities
Delete	See description	Data files and automatic programs; note files may be deleted with File Utilities
Program Edit	Program/Entry	No data entry or access to Events or Step SP/Time fields; can't insert/delete/copy/paste step
USB	Data/Utilities/USB	Allows USB memory stick to copy/delete data, alarm, program and audit trail files and to import programs
FTP/WAN	Data/Utilities/FTP/WAN	Configure FTP client settings
Communications	Device/Settings/Set/Comms	Configure web page, Modbus address and VNC settings
Tuning	Device/Settings/View/Tuning	Manual adjustment of loop tuning parameters
Set Points Limits	Device/Settings/Set/Limit	Applies to loop controls (does not apply to loop/monitor alarms)
Adjust Alarms	Device/Settings/Set/Alarm	Applies to all loop and monitor point alarms
Event Names	Device/Settings/Set/Event	Configure event tagnames (seen in manual Events and program step Events)
E-mail Settings	Device/Settings/E-mail/E-mail Settings	Configure e-mail settings and addresses
E-mail Message	Device/Settings/E-mail/Message	Access to compose and send e-mail message
Offline	Device/Settings/Offline	Access to Off-Line menu system: Units, set Clock, Calibrate Touch, Language, Exit to Application, input Offset, Configuration
Calibrate Touch	Device/Settings/Offline/System/Display	Access to the touch screen calibration utility
Backlight	Device/Settings/Offline/System/Display	Access to edit backlight settings for brightness and off delay time
Alarm Volume	Device/Settings/Offline/System/Display	Allows edit of the Touch Screen alarm beeper volume
Units	Device/Settings/Offline/Set/Units	Loop/monitor point temperature units configuration – C/F
Clock	Device/Settings/Offline/Set/Clock	Set Data/Time, Time Zone, DST and NTS connection
NTP	Device/Settings/Offline/Set/Clock	Enable and chose National Time Server location
Daylight Savings	Device/Settings/Offline/Set/Clock	Enable Daylight Savings Time (DST)
Language	Device/Settings/Offline/Set/Language	Select help language
Security	View/Security/Configure	Applies to Security Setup

System Security User Access List (continued)

User right	Menu Location	Description
Configuration	Device/Settings/Offline/System/Configuration	Access to import/export setup files of the Touch screen
Default Configuration	Device/Settings/Offline/System/Configuration; Reset Default Configuration button	Function to clear system configuration and reset all to blank (default) state for reconfiguring
Exit (run mode)	Device/Settings/Offline/System/Exit; "Exit application. (automatic mode startup)." Button	Prevents the Touch Screen application from being stopped
Exit to Configurator	Device/Settings/Offline/System/Exit; "Exit application. (configuration mode startup)." Button	Prevents from the Touch Screen application from being stopped and access to the Touch Screen configurator application
Tuning	Device/Settings/View/Tuning	Manual adjustment of loop tuning parameters
Set Points Limits	Device/Settings/Set/Limit	Applies to loop controls (does not apply to loop/monitor alarms)
Adjust Alarms	Device/Settings/Set/Alarm	Applies to all loop and monitor point alarms
Event Names	Device/Settings/Set/Event	Configure event tagnames (seen in manual Events and program step Events)
E-mail Settings	Device/Settings/E-mail/E-mail Settings	Configure e-mail settings and addresses
E-mail Message	Device/Settings/E-mail/Message	Access to compose and send e-mail message
Offline	Device/Settings/Offline	Access to Off-Line menu system: Units, set Clock, Calibrate Touch, Language, Exit to Application, input Offset, Configuration
Calibrate Touch	Device/Settings/Offline/System/Display	Access to the touch screen calibration utility
Backlight	Device/Settings/Offline/System/Display	Access to edit backlight settings for brightness and off delay time
Alarm Volume	Device/Settings/Offline/System/Display	Allows edit of the Touch Screen alarm beeper volume
Units	Device/Settings/Offline/Set/Units	Loop/monitor point temperature units configuration – C/F
Clock	Device/Settings/Offline/Set/Clock	Set Data/Time, Time Zone, DST and NTS connection
NTP	Device/Settings/Offline/Set/Clock	Enable and chose National Time Server location
Daylight Savings	Device/Settings/Offline/Set/Clock	Enable Daylight Savings Time (DST)
Language	Device/Settings/Offline/Set/Language	Select help language
Security	View/Security/Configure	Applies to Security Setup
Configuration	Device/Settings/Offline/System/Configuration	Access to import/export setup files of Touch Screen
Default Configuration	Device/Settings/Offline/System/Configuration; Reset Default Configuration button	Function to clear system configuration and reset all to blank (default) state for reconfiguring
Exit (run mode)	Device/Settings/Offline/System/Exit; "Exit application. (automatic mode startup)." Button	Prevents the Touch Screen application from being stopped
Exit to Configurator	Device/Settings/Offline/System/Exit; "Exit application. (configuration mode startup)." Button	Prevents from the Touch Screen application from being stopped and access to the Touch Screen configurator application

Appendix B - Troubleshooting

The following Touch Screen alert messages and operating conditions will occur when the warming cabinet is operating outside of acceptable conditions.

Alarm Monitor Description	Explanation/Corrective Action
Over temperature alarm is activated	<ol style="list-style-type: none"> 1. Is the circulating fan operational? 2. Are the contents loaded properly? 3. Has the chamber set temperature been lowered? 4. Temperature of the lower chamber cannot be in excess of +30°F (+1.1°C) above the upper chamber. 5. Contact your MAC Medical authorized service representative. <p>When the cabinet temperature exceeds the set point by 10°F (or by 5°C) or the set temperature is lowered by more than 10°F (or by 5°C), the display will flash the Alarm icon and the audible alarm will sound.</p> <p>Turn off the Warming Cabinet chamber and wait for the contents to cool adequately. Then unload the contents using personal protective equipment to avoid injury. Reload the contents using the proper loading guidelines as previously mentioned in this manual.</p> <p>Turn on the chamber and monitor performance. If the chamber continues to overheat into an alarm condition, turn off the chamber and contact your MAC Medical authorized service personnel.</p>
"tagname" A to D converter failure	(error code 40) Indicates that the analog to digital converter in the loop controller indicated by "tagname" has failed. Return to factory for repair or replace.
Auto tune failed for "tagname"	(error code 26) Indicates that auto tune was unable to execute properly for the loop controller indicated by "tagname" Verify that PB>0 and TI>0 before starting auto tune. Try manual tuning instead of auto tuning if the process has a very slow response.
"tagname" cold junction failure	(error code 30) Indicates that the cold junction compensation in the loop controller indicated by "tagname" has failed. Return to factory for repair and replace.
Communications error with "tagname". Check cable.	Check communication wiring between COM2 of the Touch Screen touch screen and the loop controller indicated by "tagname" Verify that the loop control has the proper communications address and communications settings.
"tagname" EEPROM failure	(error code 29) Indicates that the memory in the loop controller indicated by "tagname" has failed. Return to factory for repair or replace.
E-mail Error! Check cable or server down.	Indicates that the Touch Screen was unable to send an alarm message through the mail server. Verify that the Touch Screen is properly connected to the network and that the e-mail settings and addresses are valid.
FTP! Check cable or server down.	Indicates that the FTP back-up attempt of the data files failed. Verify that the Touch Screen is properly connected to the network and that the FTP settings are valid. <i>If nCompass is not connected to a network, disable the FTP data back-up to prevent seeing this alarm.</i>
NTP Ping Failed. Check Cable.	Indicates that the Touch Screen was unable to synchronize its clock with the selected national time server. Verify that the Touch Screen is properly connected to the network and the selected time server is accessible. <i>If the Touch Screen is not connected to a network, disable the NTS clock to prevent seeing this alarm.</i>
"tagname" outputs 1 and 2 incorrectly configured.	(error code 4) Indicates that the control loop configuration for the loop controller indicated by "tagname" is not valid and must be corrected to clear the alarm. Check and correct setup values of output 2, PB, TI and output 1. If output 2 is required for cooling control, the control should use PID mode (PB > 0, TI > 0) and output 1 should use reverse mode (heat action), otherwise don't use output 2 for cooling control.
Program run error. "Loop 1" and "Loop 2" are not synchronized.	Alarm applies to dual loop Touch Screen systems only and indicates that the running program (in each loop control) is operating with a difference of more than 1 minute between the steps programmed for each loop. NOTE: This alarm does not affect program operation. In order to clear the alarm, the program will have to be stopped. If the alarm will not clear, but the program indicates it is off, select "Stop" from the Program menu and then try to clear the alarm again. The timing accuracy of the Touch Screen loop controls is + 30 seconds per month. This may cause one loop control to execute the program slightly faster than the other. For programs with long term operation, weeks of months, one loop may get significantly ahead of the other causing it to begin its next ramp or soak step ahead of the other affecting product or test results. Verify that the program end set point configuration for each loop is set to the same function. Verify that the event input functions (if used) are configured for the same function.
"tagname" sensor break	Check sensor wiring for the loop controller indicated by "tagname". Verify lead connections. If sensor requires power, verify power to sensor.

General Troubleshooting Issues

Chamber does not heat -

1. Is the power turned on?
2. Is the temperature set above chamber ambient temperature?
3. Is the circulation fan operational? Check Output voltage on the relay.
4. Is there voltage on the output terminal of the controller?
5. Is the door(s) closed?
6. Contact your MAC Medical authorized service representative

Unit will not power up -

1. Check outlet for power
2. Check if warmer is plugged in
3. Check if the ON/OFF switch/circuit breaker is turned on
4. Check the fuse on the incoming supply
5. Check for power at the junction box in the control panel
6. Contact your MAC Medical authorized service representative

Audible alarm and HI message alert -

- The alarm is activated when actual temperature exceeds the set point by ten degrees.

Audible alarm and HI message alert (Upper Chamber Only) -

- Possible heat transfer from lower unit.
- The temperature of the lower unit can be no more than 30°F greater than the temperature of the upper unit.
- This problem can be prevented by lowering the temperature of the lower unit or by reversing the contents of the two compartments.

TS-Series Electronic Connections Diagrams

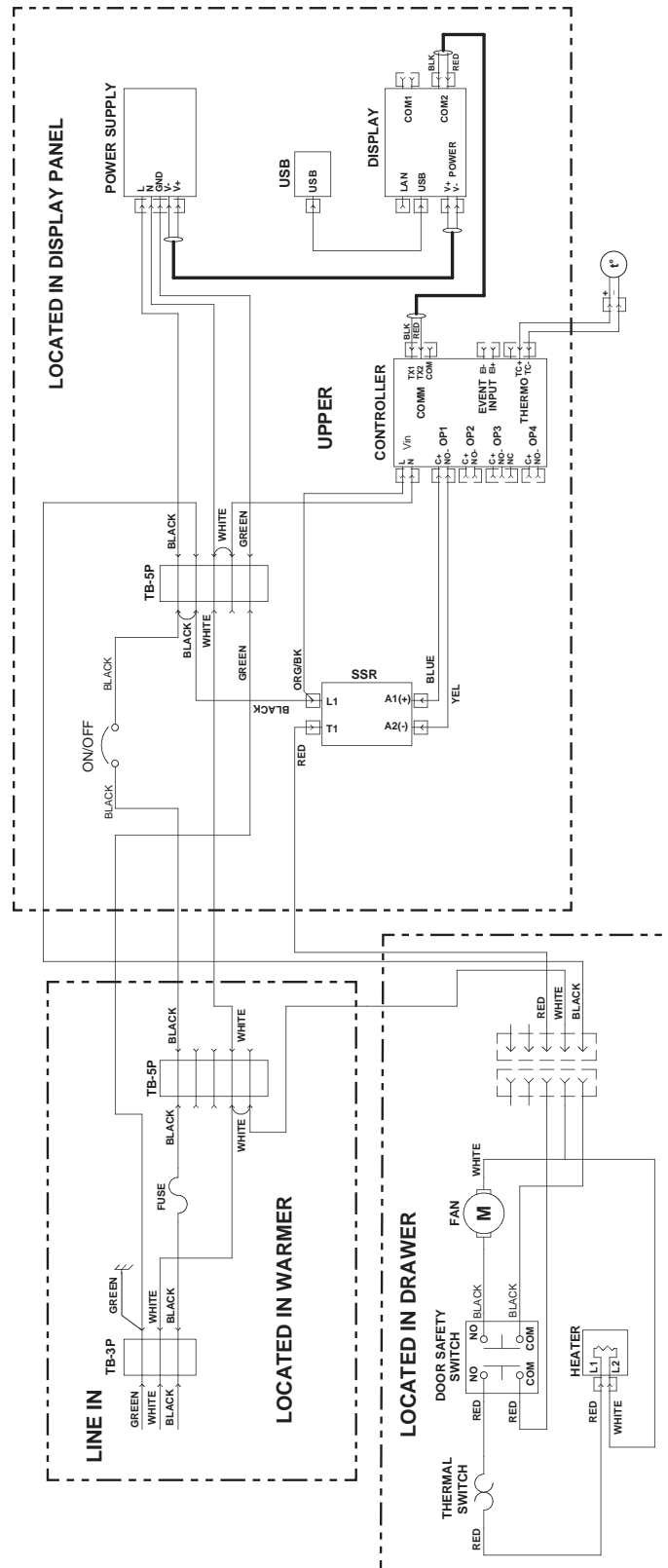

Fig. 186: Connections for USB 120V Single Warming Cabinet

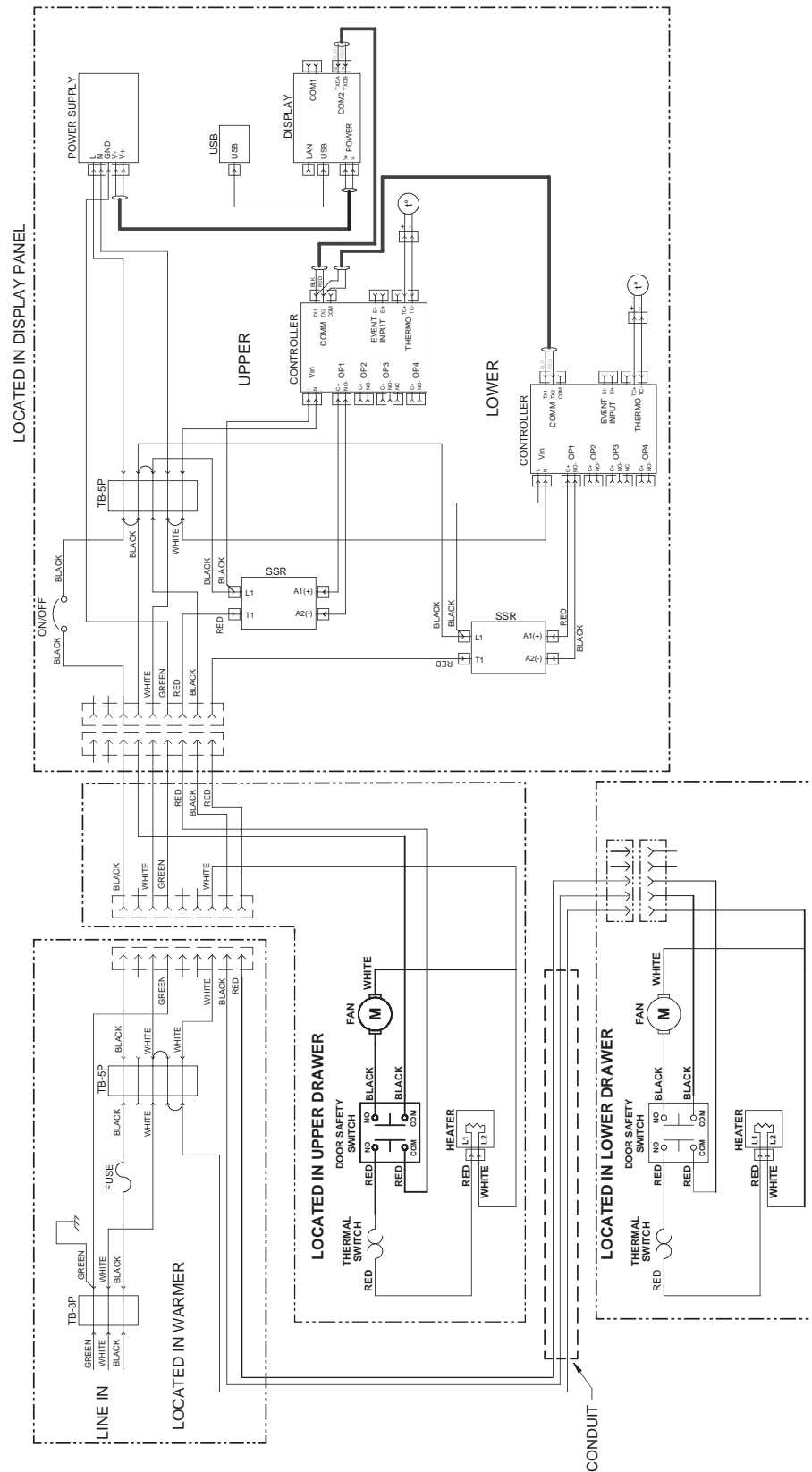

Fig. 187: Connections for USB 120V Dual Warming Cabinet

Index

C

Cabinet Bases, Mobile Bases and Mobile Stands 61

Cleaning 56

- Approved cleaning materials and agents 56
- Decals or Printed Labels 56
- Glass Doors 56
- Prohibited Cleaning Materials & Agents 56
- Stainless Steel Surfaces 56

D

Door Hinge Reversal 62

- Glass Doors 66
- Steel Doors 69

I

Installation 12

- Direct Wiring to Facility Power Supply 14
- Environmental Conditions 12

M

Maintenance 57

- Daily Checklist 57
- Monthly Checklist 57
- Semi-Annual Checklist 57
- Weekly Checklist 57

O

Operation 15

- Items permitted for warming 15
- Items prohibited for warming 15
- Power Failure 15
- Proper Content Loading 15
- Recommended Settings 15
- Turning off the Warming Cabinet 55
- Unloading the Warming Cabinet 55

P

Patient Safety

- Maximum Warming Temperature Limit 55

R

Replacement Parts

- General 58
- Header Assembly and Electrical Drawer 59

S

Shelves

- Adjusting 53
- Installation 53
- Roller Basket
 - Adjusting 54
 - Installation 54
 - Part Numbers 61

Specifications 7

- Cabinet Construction and Material 7
- Electrical Specifications 7
- Factory Presets 7
- Power Requirements 7

T

Temperature Issues

- Checking Accuracy 57
- Single and Dual Chamber Temperature Setting 22
- Switching Temperature Units 23
- Temperature Set Points 22
- Temperature Tolerances 22

Touch Screen

- Alarm Function 35
- Annotation 33
- Audit Trail 21
- Charts and Chart Setup 27
 - Accessing Historical Data 29
 - History Plot Setup 28
- Clock Settings 39
 - Adjust Time Tab 39
 - Daylight Tab 40
- Communications 45
 - Configuring the Touch Screen Network 45
 - Ethernet Communications 45
 - Obtaining the Touch Screen MAC Address 45
 - Setting a Static IP Address 46
- Communication Setting 38
- Configuration 43
- Data File Naming 25
- Digital Signatures 34
- Display Settings 42
 - Alarm Volume 42
 - Backlight Settings 43
 - Calibrate Touch 42
- E-mail Function 36
 - Add E-mail Address 36
 - E-mail Address Management and Settings 36
 - E-mail Settings 36
 - Sending an E-mail Message 37
 - Viewing E-mail Address List 36
- Exit Application 44

- FTP/WAN Backup 32
- Interface 16
- Language 40
- Navigation 19
- Notifications 22
- Offset Calibration 41
- Quick Setup 17
 - Set up Default Supervisor Account 17*
 - User Security Levels 18*
- Serial Communications Option 52
- Switching Temperature Units 23
- USB File Transfer 30
- User Accounts 20
 - Change User Password 20*
 - Set Password Aging 21*
 - Setting User Access 21*
- User Login/Log Off 19
- VNC Server, using
 - Accessing Touch Screen through a VNC Viewer 50*
 - Recommended VNC Viewer Settings for Tablets 50*
 - Recommended VNC Viewer Settings (PC/MAC) 48*
 - VNC Viewer, multiple instances 51*
- Web Server, using 48
- Troubleshooting 74**

U

Unpacking 11

- Inspection 11
- Receiving Requirements 11

W

Warming Cabinets

- Interior Dimensions & Capacity 5
- Main Features 8
- Models 4
- Overall Size 4
- Patient Safety - Max Warming Temperature Limit 55
- Turning Off 55
- Unloading 55
- Usable Chamber Space 6

Warnings and Cautions 9

- Intended Use Notice 10
- Special User Attention 10

Warranty Information 83

Warranty Information



Limited Lifetime Warranty

MAC Medical warrants to the original purchaser that its Proprietary Products will be free from defects in workmanship or materials under normal use and service for the life of the product, so long as owned by the original purchaser, according to the limitations set forth below. Defective products shall be repaired or replaced at MAC Medical's option at no cost to the original purchaser provided:

1. The customer must obtain a written return authorization supplied by MAC Medical's customer service department. The product must be returned, properly packaged, with a copy of the original sales receipt and copy of the RMA authorization. Please call (877) 828-9975 or (618) 476-3550 to receive a return authorization.
2. The customer must pre-pay freight charges to and from MAC Medical and must ship merchandise properly packaged, in a way the product will not be damaged during transit to the factory. MAC Medical does not warranty any freight damage to or from the factory. It is the customer's responsibility to inspect the product for packaging damage before signing the BOL.

This warranty does not apply to products, which have been subject to abuse, misuse, accident, modification, alteration, tampering, negligence, lack of routine maintenance or misapplication; or products that have been repaired by other than MAC Medical or its authorized representatives.

This warranty does not apply to glass, fabrics, vinyl, seat coverings, cushions, padding or their stitching, gluing or installation. Component parts not manufactured by MAC Medical, such as casters, caster inserts, any components made from rubber or plastic, circuit boards, fan heaters, plumbing parts, electrical switches and other components are also excluded. For these component parts, MAC Medical will pass on the original manufacturer's warranty to MAC Medical equipment original purchasers. Please consult factory for questions regarding the warranties of these component parts. This warranty does not apply to custom fabricated products. Consult factory.

UNLESS EXPRESSLY SET FORTH IN THIS WARRANTY, THERE ARE NO OTHER WARRANTIES, WHETHER EXPRESS OR IMPLIED, OF FITNESS AND / OR MERCHANTABILITY OR ANY OTHER WARRANTY IMPLIED BY CUSTOM, USAGE OR COURSE OF DEALING.

Liability of MAC Medical under this warranty is limited to the repair and / or replacement of any products. MAC Medical specifically excludes and disclaims any responsibility for any incidental or consequential damages claimed to have arisen from any defect in workmanship or materials. No representative has any authority to change or enlarge the above warranty or MAC Medical liability. This supersedes all previous warranty provisions.

To place an order, contact our customer service department at **618-476-3550** or **877-828-9975** or by email at sales@macmedical.com

MADE
IN THE **USA**

INSPIRED
TO BE BETTER

MAC Medical, Inc.
Printed in USA
Publication No. MAN-022 Rev I
June 2026

Information regarding this product is subject to change without prior notice.



Corporate Office
609 S. Breese St.
Millstadt, IL 62260

Manufacturing Plant
820 South Mulberry Street
Millstadt, IL 62260

Phone: 618-476-3550 • Toll Free: 877-828-9975 • www.macmedical.com