



# INSTRUCTION MANUAL



## Case Carts

### Usage and Maintenance



Read and understand all of the instructions and safety information in this manual before operating this product.

## Table of Contents

|  |    |
|--|----|
| Recommended Usage.....                                   | 3  |
| Warnings When Operating This Product.....                | 3  |
| Case Cart Types.....                                     | 4  |
| Standard Features (Closed Cart).....                     | 5  |
| Optional Features of the Closed Case Cart.....           | 5  |
| Model Numbers and Case Dimensions.....                   | 5  |
| Standard Features (Sealed Cart).....                     | 6  |
| Optional Features of the Sealed Case Cart.....           | 6  |
| Model Numbers and Case Dimensions.....                   | 6  |
| Standard Features (Open Cart).....                       | 7  |
| Optional Features for the Open Case Cart.....            | 7  |
| Model Numbers and Case Dimensions.....                   | 7  |
| Standard Features (Vertical Handle Cart).....            | 8  |
| Optional Features for the Vertical Handle Case Cart..... | 8  |
| Model Numbers and Case Dimensions.....                   | 8  |
| Parts of the Closed Case Cart.....                       | 9  |
| Parts of the Sealed Case Cart.....                       | 9  |
| Parts of the Open Case Cart.....                         | 10 |
| Parts of the Vertical Handle Case Cart.....              | 10 |
| Unpacking Instructions.....                              | 11 |
| Closed Cart and Vertical Handle Case Cart Operation..... | 12 |
| Adjusting Shelves.....                                   | 12 |
| Bolt-On Features.....                                    | 15 |
| Optional Features.....                                   | 16 |
| Casters and Wheels.....                                  | 18 |
| Cleaning and Maintenance.....                            | 20 |
| Replacement Parts - General.....                         | 22 |
| Preventative Maintenance Record.....                     | 23 |
| Warranty Information.....                                | 24 |

### DESCRIPTION OF PRODUCT

The products covered in this manual are closed, open & sealed case carts, and vertical handle case carts.

### PURPOSE OF THIS MANUAL

This manual covers case cart use, surface care and cleaning and parts maintenance.

## ***KEEP THIS MANUAL***

## Recommended Usage

Case Carts are transport vehicles intended to secure and convey items such as instrument sets and surgical supplies from the Sterile Processing Department of the healthcare facility to the Operating Room and back again for reprocessing.

For these products to be used correctly, certain safety precautions must be adhered to. The precautions for use are:

- Take care when transporting the cart (i.e. doors properly secured and wheels unlatched).
- Doors should be closed during transport and when populated with supplies needed for surgery.
- A document holder is provided on most models to hold pick lists or other necessary information.
- Recommended shelf weight capacities are listed on pages 5-8.
- Once items have been removed, the cart may remain for transport of used items.
- Staff handling contaminated items must follow facility guidelines and standard precautions.
- After use, the cart should be properly decontaminated (see Cleaning and Maintenance).
- Once cleaned, the cart should be inspected for damage or wear. For example, shelves should be properly secured, doors should close and open easily, and wheels should be free of obstructions.
- If necessary or deemed faulty, case cart should be taken out of service for maintenance or repair.
- Care should be taken when loading the cart, i.e. heavier sets placed on lower shelves. Do not stack wrapped trays as this may compromise their ability to maintain a sterile barrier. Tears will require reprocessing of the set.
- Sterilization containers should be placed flat on the shelf. Two (2) containers may be stacked, one on top of the other, for transport.
- OPTIONAL: When contaminated items are transported in the case cart, the cart should be clearly labeled. MAC Medical provides a sliding or wheel Disposition Monitor whereby contents are identified with visible signage indicating that the contents are "CLEAN" or "DIRTY" (not safe for handling without taking proper protective precautions). In addition, MAC Medical also provides tamper-evident stainless steel tabs.

## Warnings When Operating This Product

Prior to operation, the user must read these warnings.

The following is a list of the safety precautions that must be observed when operating this equipment.



**WARNING - INJURY HAZARD -**

**ALWAYS TEAM LIFT THE CASE CART**

**DO NOT PUT HANDS UNDER CASE CART**

**DO NOT OPERATE THE CASTERS WITH HANDS**

**TO AVOID INJURY USE HANDLE TO MANEUVER CART**

**TIP HAZARD - ONLY ROLL OUT ONE SHELF AT A TIME**

## Case Cart Types



Closed Case Cart - for securely and sterilely transporting instruments and surgical supplies



Sealed Case Cart - for securely and sterilely transporting instruments and surgical supplies behind locked and sealed doors



Open Case Cart - for transporting or storing hospital supplies



Vertical Handle Case Cart - for easier movement of large cabinets

## Standard Features (Closed Carts)

### Closed Case Carts come standard with:

- Fully welded construction with inner skeletal system for strength and our easy service bolt-on features
- Soundproof tops and doors for quiet operation
- 6" maintenance-free, high temp, high pressure stainless steel casters with sealed ball bearings (3 swivel & 1 fixed directional)
- Bolt-on exterior push handle for better control
- Bolt-on full wrap-around non-marring bumper assembly
- Bolt-on door hinges
- Bolt-on positive lock door latches
- Bolt-on 8.5" x 11" card holder
- Bolt-on tamper evidence security hasps



## Optional Features of the Closed Case Cart:

- Glass door(s)
- Etching for serial tag ID/tracking
- Etching for end user logo
- Adjustable solid shelf (non roll out - 300LB capacity)
- Adjustable solid shelf (roll out - 200LB capacity)
- Adjustable perforated shelf (non roll out - 300LB capacity)
- Adjustable perforated shelf (roll out - 200LB capacity)
- Adjustable wire shelf (non roll out - 150LB capacity)
- Adjustable wire shelf (roll out - 150LB capacity)
- Side extensions
- Flag system (one each of red, yellow and green)
- Clean/dirty indicator (slide or wheel)
- Total locking casters
- Tow hitch

## Model Numbers and Case Dimensions (Includes all models)

| Model   | Case Dimension |        |        | OA Dimension |        |        | Doors |
|---------|----------------|--------|--------|--------------|--------|--------|-------|
|         | Depth          | Width  | Height | Depth        | Width  | Height |       |
| MMCCB2  | 28.5           | 28.5   | 47     | 30.375       | 34     | 54.625 | 1     |
| MMCCB3  | 25             | 40.25  | 32     | 26.875       | 45.75  | 39.625 | 2     |
| MMCCB4  | 25             | 40.25  | 47     | 26.875       | 45.75  | 54.625 | 2     |
| MMCCB5  | 25             | 36     | 47     | 26.875       | 41.5   | 54.625 | 2     |
| MMCCB6  | 25             | 23.625 | 32     | 26.875       | 29.125 | 39.625 | 1     |
| MMCCB7  | 24.25          | 36.25  | 47     | 26.125       | 41.75  | 54.625 | 2     |
| MMCCB8  | 25             | 23.341 | 32     | 26.875       | 28.841 | 39.625 | 1     |
| MMCCB9  | 25             | 23.625 | 47     | 26.875       | 29.125 | 54.625 | 1     |
| MMCCB12 | 25             | 36     | 32     | 26.875       | 41.5   | 39.625 | 2     |
| MMCCB14 | 25.875         | 46.5   | 32     | 27.75        | 52     | 39.625 | 2     |
| MMCCB15 | 25.875         | 46.5   | 47     | 27.75        | 52     | 54.625 | 2     |

## Standard Features (Sealed Carts)

*Sealed Case Carts come standard with:*

- Fully welded construction
- Soundproof tops and doors for quiet operation
- Exterior push handle for better control
- Door gaskets for increased dust control
- Locking rods to keep doors secure
- Full wrap around non-marring heavy-duty bumper
- Magnetic door catches to keep doors open while in use
- 8.5" x 11" card holder
- Tamper evidence security tabs
- 6" maintenance-free, high-temperature, high-pressure stainless steel casters with sealed ball bearings (2 rigid & 2 swivel with brake)



Shown with Optional Clean/Dirty Wheel Indicator

## Optional Features of the Sealed Case Cart:

- Etching for serial tag ID/tracking
- Etching for end user logo
- Adjustable solid shelf (non roll out - 300LB capacity)
- Adjustable solid shelf (roll out - 200LB capacity)
- Adjustable perforated shelf (non roll out - 300LB capacity)
- Adjustable perforated shelf (roll out - 200LB capacity)
- Adjustable wire shelf (non roll out - 150LB capacity)
- Adjustable wire shelf (roll out - 150LB capacity)
- Side extensions
- Flag system (one each of red, yellow and green)
- Clean/dirty indicator (slide or wheel)
- Total locking casters
- Tow hitch

## Model Numbers and Case Dimensions (Includes all models)

| Model   | Case Dimension |        |        | OA Dimension |        |        | Doors |
|---------|----------------|--------|--------|--------------|--------|--------|-------|
|         | Depth          | Width  | Height | Depth        | Width  | Height |       |
| MMSCC2  | 29             | 29.5   | 47     | 30.875       | 35     | 54.5   | 1     |
| MMSCC3  | 25.5           | 41.25  | 32     | 27.375       | 46.75  | 39.5   | 2     |
| MMSCC4  | 25.5           | 41.25  | 47     | 27.375       | 46.75  | 54.5   | 2     |
| MMSCC5  | 25.5           | 37     | 47     | 27.375       | 42.5   | 54.5   | 2     |
| MMSCC6  | 25.5           | 24.625 | 32     | 27.375       | 30.125 | 39.5   | 1     |
| MMSCC7  | 24.75          | 37.25  | 47     | 26.625       | 42.75  | 54.5   | 2     |
| MMSCC8  | 25.5           | 24.341 | 32     | 27.375       | 29.841 | 39.5   | 1     |
| MMSCC9  | 25.5           | 24.625 | 47     | 27.375       | 30.125 | 54.5   | 1     |
| MMSCC12 | 25.5           | 37     | 32     | 27.375       | 42.5   | 39.5   | 2     |
| MMSCC14 | 26.375         | 47.5   | 32     | 28.25        | 53     | 39.5   | 2     |
| MMSCC15 | 26.375         | 47.5   | 47     | 28.25        | 53     | 54.5   | 2     |

## Standard Features (Open Cart)

*Open Case Carts come standard with:*

- Open design
- Heavy built cart
- Full wrap-around non-marring bumper
- Adjustable stainless steel shelves
- Stainless steel guard rail
- 6" composite directional locking casters

## Optional Features for the Open Case Cart:

- Wire grid on back side
- Fixed shelving
- Adjustable solid shelf (non roll out - 300LB capacity)
- Adjustable perforated shelf (non roll out - 300LB capacity)
- Adjustable wire shelf (non roll out - 150LB capacity)
- 6" Maintenance-free, high temp, high-pressure stainless steel casters with sealed ball bearings
- Total locking casters
- 6" Plastic bin
- 10" Plastic bin



## Model Numbers and Case Dimensions

| Model   | OA Dimension |        |        |
|---------|--------------|--------|--------|
|         | Depth        | Width  | Height |
| MMOCC13 | 29.375       | 40.375 | 37.5   |
| MMOCC16 | 26.125       | 60.375 | 67.25  |
| MMOCC18 | 27           | 40.75  | 37     |
| MMOCC19 | 30.875       | 40.75  | 39     |
| MMOCC21 | 29.75        | 29.75  | 62     |
| MMOCC24 | 24           | 30     | 54     |
| MMOCC25 | 24           | 24     | 54     |



## Standard Features (Vertical Handle Case Cart)

*Vertical Handle Case Carts come standard with:*

- Ergonomically friendly vertical handles for precise control
- Fully welded construction
- 8.5" x 11" card holder
- Soundproof tops and doors for quiet operation
- Full wrap-around non-marring bumper
- Tamper evidence security haps
- Positive lock door latches
- 6" maintenance-free, high temp, high-pressure stainless steel casters with sealed ball bearings, three swivel and one directional lock

## Optional Features for the Vertical Handle Case Carts:

- Glass Door(s)
- Etching for serial tag ID/tracking
- Etching for end user logo
- Adjustable solid shelf (non roll out - 300LB capacity)
- Adjustable solid shelf (roll out - 200LB capacity)
- Adjustable perforated shelf (non roll out - 300LB capacity)
- Adjustable perforated shelf (roll out - 200LB capacity)
- Adjustable wire shelf (non roll out - 150LB capacity)
- Adjustable wire shelf (roll out - 150LB capacity)
- Side extensions
- Flag system (one each of red, yellow and green)
- Clean/dirty indicator (slide or wheel)
- Tow hitch
- Cool touch handles
- Total locking casters
- Silicon door gasket for complete sterility control



## Model Numbers and Case Dimensions

| Model           | Case Dimension |        |        | OA Dimension |       |        | Doors |
|-----------------|----------------|--------|--------|--------------|-------|--------|-------|
|                 | Depth          | Width  | Height | Depth        | Width | Height |       |
| MMCV95-2PS-SSD  | 26.5           | 39.625 | 40.75  | 27.75        | 48.25 | 53.5   | 2     |
| MMCV107-2PS-SSD | 24.75          | 40     | 38.75  | 26           | 48.75 | 51     | 2     |



## Parts of the Closed Case Cart

The image below shows the exterior view of a typical Closed Case Cart.

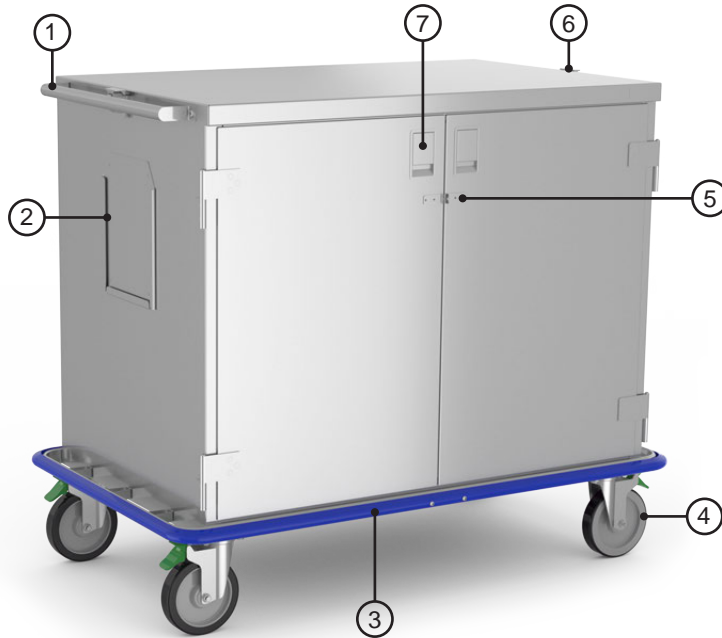

1. Push Handle
2. 8.5" x 11" Card Holder
3. Bumper Guard
4. Casters and Wheels (with foot-operated green lock on one directional lock wheel)
5. Tamper Evidence Security Hasps
6. Door Catches
7. Door Latches

## Parts of the Sealed Case Cart

The image below shows the exterior view of a typical Sealed Case Cart.



1. Push Handle
2. 8.5" x 11" Card Holder
3. Bumper Guard
4. Casters and Wheels (with foot-operated green lock on one directional lock wheel)
5. Secure Locking Door Handle
6. Tamper Evidence Security Hasps
7. Magnetic Door Catches

## Parts of the Open Case Cart

The image below shows some of the features of a typical Open Case Cart.



1. Casters and Wheels (with foot-operated green lock on one directional lock wheel)
2. Bumper Guard
3. Fixed Bottom Shelf (non roll out)
4. Adjustable Shelves (non roll out)

## Parts of the Vertical Handle Case Cart

The image below shows the exterior view of a typical Vertical Handle Case Cart.



1. Vertical Handles
2. 8.5" x 11" Card Holder
3. Bumper Guard
4. Casters and Wheels (with foot-operated green lock on one directional lock wheel)
5. Tamper Evidence Security Hasps
6. Door Catches
7. Door Latches

## Unpacking Instructions

### Receiving Requirements

The customer is responsible for making sure the loading dock at their facility can accommodate a skid-mounted case cart approximately 60" x 50" x 70". The customer must also provide transportation equipment (forklift, etc.) for a case cart and skid weighing approximately 300 lb.

### Inspection

1. Receiving area must meet all State and Local regulations prior to unpacking.
2. Customer must inspect skid and Case Cart both before and after unpacking to determine if any items were damaged during shipping.
3. All damaged items must be listed on the Bill of Lading.
8. Customer is responsible for the proper disposal of all packing materials. The disposal of these items must meet all State and Local regulations.

### Unpacking The Case Cart

Case Carts are shipped on well-constructed wooden skids. Four steel bands secure the Cart to the skid. The stainless steel surfaces of the Cart are protected by heavy cardboard and foam padding, and layers of plastic wrapping (Fig. 1). The wheels and casters of the Case Cart are protected by styrofoam blocks (Fig. 2).

Care must be taken while unpacking the Case Cart to avoid damage. Do not drop tools on the Case Cart or scratch the surfaces with sharp edges.

**IMPORTANT:** Wear gloves and eyewear during the unpacking operation.

**IMPORTANT:** At one point during the unpacking operation, at least two men or a hand-operated forklift will be needed to safely move the Cart from the wooden skid.

Retain all shipping materials until the Case Cart is completely unpacked and inspected for damage.

1. Use tin snips to cut the metal bands holding the case cart to the wooden pallet.
2. Using two men or a hand-operated forklift, lift the cart off the wooden skid and off the styrofoam blocks. (**NOTE:** the foam blocks are glued to the wooden skid.) Place the Cart on the floor.
3. Remove all protective packing material.
  - A.  **Caution:** DO NOT use a box cutter or any other cutting utensil to remove the plastic protective wrapping around the Case Cart. These items can scratch the protective coating on the stainless steel, allowing the surface to rust.
4. The Case Cart is now ready for use.
5. Discard shipping and packing materials in compliance with Local and State regulations.



Fig. 1: Steel Bands and Padding



Fig. 2: Foam Blocks Protecting Casters

## Closed Cart and Vertical Handle Case Cart Operation

Remove all protective covering from the exterior of the cart. Covering must be removed before placing the cart into service.



Fig. 3: Door Latches

**Doors** - To open, lift up on door latch paddle to open the door(s). On double door units, the right door must be opened before the left door. To close, swing door(s) back into cart, with the right door overlapping the left (Fig. 3).

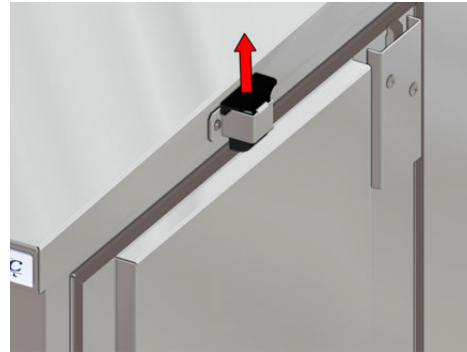

Fig. 4: Door Catches

**Door Catch** - To lock the door in the open position, rotate the door(s) to lie against the side of the unit. Pull the door catch up and push the door against the side of the unit. Release the catch to lock the door in place. To close the door, pull the door catch up to release it and close the door (Fig. 4).

## Adjusting Shelves

Case Carts can contain solid, perforated or wire shelves. These shelves can be adjusted for various heights within the unit. Shelf liners are not recommended.

### Locking Shelves

The shelves can be locked into place in the unit with the shelf latches.



Fig. 5: Rotate Shelf Latch

To lock a shelf, rotate the shelf latch toward the front of the shelf (Fig. 5).



Fig. 6: Snap Latch into Place

Then snap the latch into place over the shelf edge. To unlock, lift up slightly on the shelf and rotate the shelf latch back to its original position (Fig. 6).



## Removing Roll Out Shelves

To remove a roll out shelf (solid, perforated or wire), pull the shelf out along its glide until the first two rollers are visible (Fig. 7, circled in red). Then tilt up the shelf to free the first two rollers from the rail and continue to slide out until the second set of rollers are visible. Then lift out the shelf (Fig. 8).

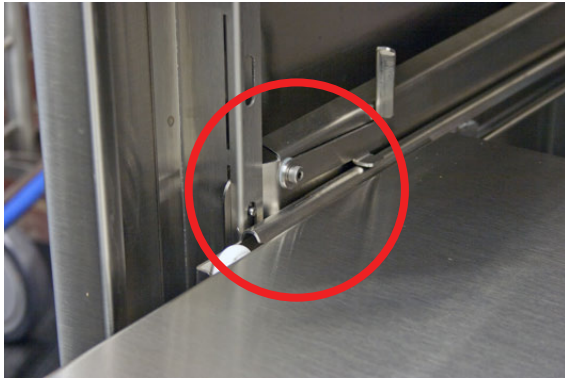

Fig. 7: Pull Shelf Till First Two Rollers Visible



Fig. 8: Pull Out Shelf

## Removing Non Roll Out Shelves

To remove a non Roll Out Shelf, pull up on the shelf arm until the arm elbows clear the slots. Then pull the arms out of the slots. Do the same for all the shelf arms and remove the shelf (Fig. 9).

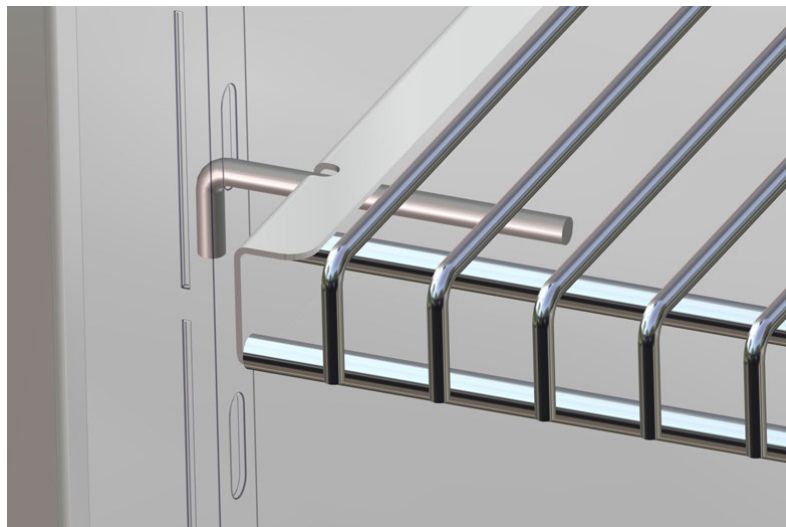

Fig. 9: Non Roll Out Shelf, Arms and Slots

## Adjusting Shelf Level for Non Roll Out Shelves

Remove the non Roll Out Shelf as described above (Fig. 9). Move the shelf to the slots on the desired level. Secure the shelf in place by inserting the shelf arms into the slots.

## Adjusting Shelf Level for Roll Out Shelves

To adjust the shelf level, first remove the shelf as detailed on Page 12 (Figs. 7 - 8) - **Removing Roll Out Shelves**.



Fig. 10: Press Release Button

Press the button to release the rail (both sides of the cabinet) so that the rails can be moved to another level (Fig. 10).



Fig. 11: Lift Rail Up

Lift the rail up so that the pin disconnects from the slotted vertical side rail (Fig. 11).



Fig. 12: Push Rail Toward Back

Push rail toward the back (Fig. 12).



Fig. 13: Tilt Rail Up

Tilt the rail up and pull forward (Fig. 13).



Fig. 14: Set Rail in New Position

To set the rail in its new position, align the rail at an angle with the rail slots at the back of the cart (Fig. 14).

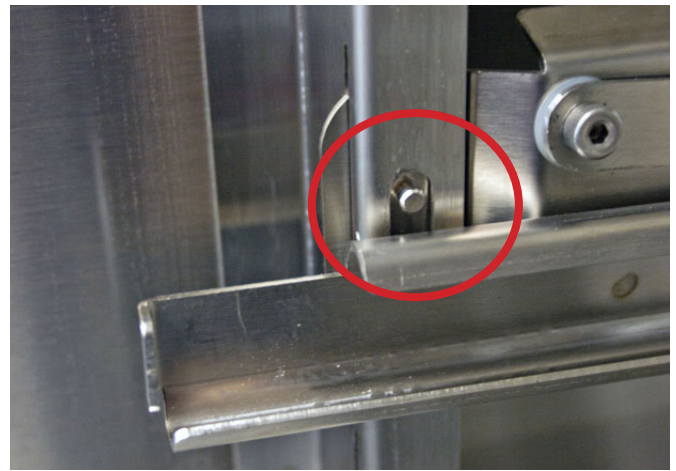

Fig. 15: Slide Rail Down and Forward

Slide the front of the rail down, making sure the pin is behind the slotted vertical side rail. Pull the rail forward and down, so that the release button appears (Fig. 15).

Reinstall the shelf after both rails have been adjusted to the new height.

## Bolt-On Features

The case cart is equipped with bolt-on features including bolt-on handles (Fig.16), bumper assembly (Fig. 17), door hinges (Fig. 18 - 19), door latches and security hasps (Fig. 20 & 21).



Fig. 16: Bolt-on Handle

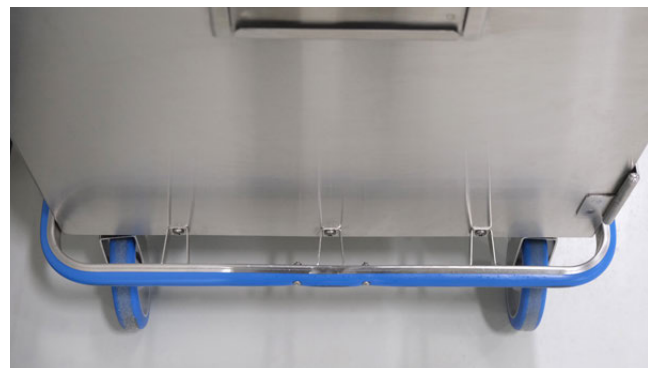

Fig. 17: Bolt-on Bumper Assembly





Fig. 18: Bolt-on Hinge (outside)



Fig. 19: Bolt-on Hinge (inside)



Fig. 20: Bolt-on Door Latch and Hasp (outside)

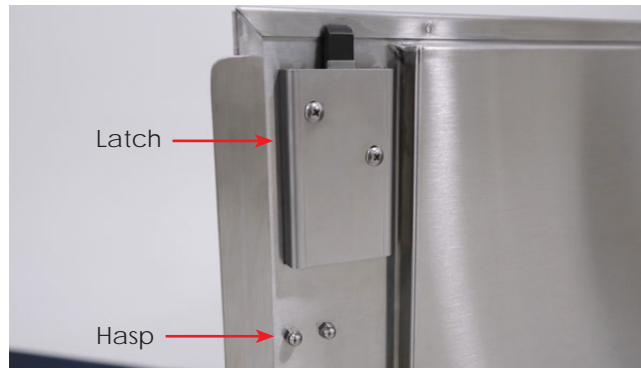

Fig. 21: Bolt-on Door Latch and Hasp (inside)

## Optional Features

### *Optional Dispositional Monitor 1 (Slide)*

When contaminated items are transported in the Closed Case Cart and Vertical Handle Case Cart, the cart should be clearly labeled. Use the slide (sliding right or left) to indicate whether the contents are clean or dirty (Fig. 22).



Fig. 22: Dispositional Monitor 1 (Slide)

### **Optional Dispositional Monitor 2 (Wheel)**

When contaminated items are transported in the Closed Case Cart and Vertical Handle Case Cart, the cart should be clearly labeled. Use the wheel (spinning clockwise or counterclockwise) to indicate whether the contents are clean or dirty (Fig. 23).

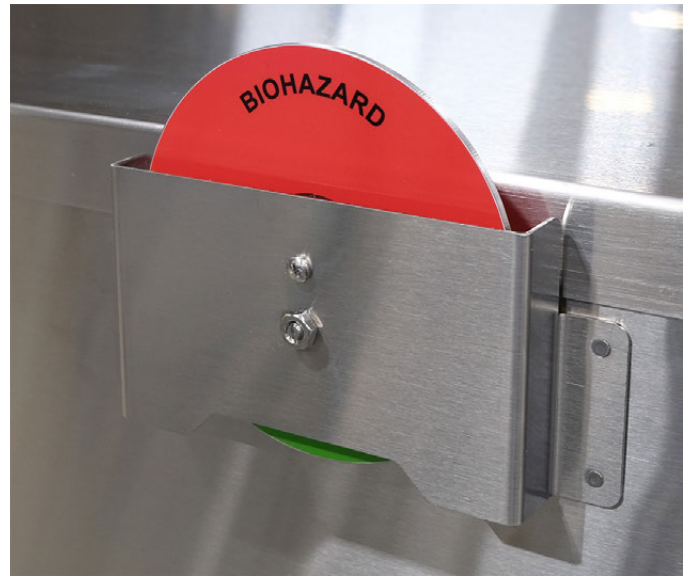

Fig. 23: Dispositional Monitor 2 (Wheel)

### **Optional Flag System**

This feature comes with three flags - Red, Green and Yellow (Fig. 24).



Fig. 24: Flag System

## Casters and Wheels

The standard wheels that come on this unit are three swivel and one directional lock caster (depending on the configuration of the cart ordered, your cart may or may not have a directional lock caster). The directional lock wheel is a foot-operated swivel lock caster.

**ATTENTION:** Directional locks are built in locks that stop the caster from swiveling. This assists the operator with steering capabilities.



Fig. 25: Lift up caster lock with foot

Lift up on the green tab to unlock the caster (Fig. 25).



Fig. 26: Push down caster lock with foot

Push down on the green tab with your foot to lock the caster (Fig. 26).

## Casters and Wheels Care and Maintenance

### Wheels:

- Periodically, the wheels should be checked for visible wear. The accumulation of certain materials such as string or thread can cause the wheel to bind and result in flat spots appearing on the wheel over time. Such wear can cause the Case Cart to be hard to steer.
- Replacement wheels should be kept on hand to keep equipment in working order.

### Casters:

- If the caster has excessive play, it may need to be replaced. Corrosion or buildup of dirt or debris can result in it not turning freely.
- Check the directional swivel lock caster to ensure it is not slipping or loose and that it turns freely. If slipping is due to a worn wheel, replace the wheel immediately.
- If the lock is not operating properly, repair or replace it and retest before returning the equipment to use.

Proper maintenance of the Wheels and Casters will ensure their proper performance and increase their lifespan.

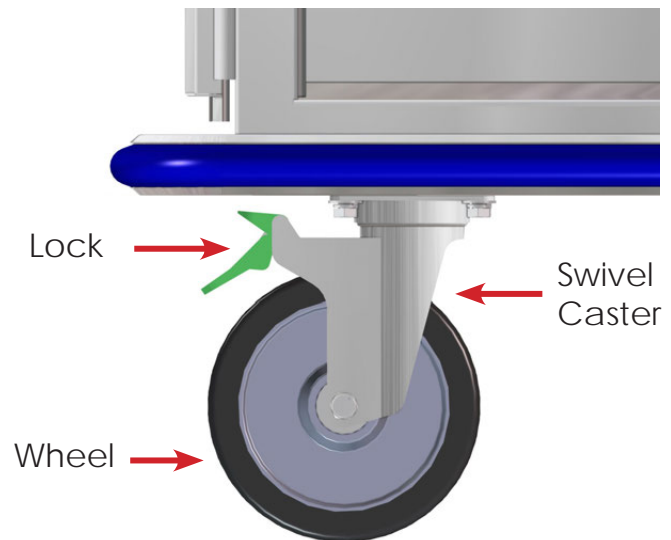

**WARNING - INJURY HAZARD -**

**DO NOT PUT HANDS UNDER CASE CART UNLESS OUT OF SERVICE FOR MAINTENANCE**

## Cleaning and Maintenance

Case Carts must be cleaned on a regular basis in order to prevent unnecessary damage to the stainless steel surface. When cleaning the Case Carts, make sure to use the proper cleaning agents and cleaning materials.



**CAUTION: DO NOT USE** the following materials on the stainless steel surfaces of Case Carts:

Abrasive Pads  
Scrapers  
Steel Wool  
Wire Brushes



**CAUTION: DO NOT USE** the following agents on the stainless steel surfaces of Case Carts:

Hard water  
Bleach or any products containing Chlorine  
Hydrochloric Acid  
Denatured Alcohol



**NOTE:** Always follow the manufacturer's directions for any chemicals used on the stainless steel surfaces of the Case Carts.

Use the following cleaning materials and agents:

Soft, clean lint-free cloth  
Distilled water  
Distilled water with mild detergent  
Cleaners approved for use on stainless steel

### ***How to Clean the Case Cart Interior***

- Open the door and remove all adjustable shelves and clips.
- Clean the adjustable shelves and shelf clips separately.
- Using a damp, lint-free cloth and approved cleaner, wipe down the interior of the Case Cart.
- Use a lint-free dry cloth to dry the Case Cart interior or let air dry. If air drying, ALWAYS leave the Case Cart doors open.

## **How to Clean the Case Cart Exterior**

### Stainless Steel:

1. Use a commercially prepared stainless steel cleaner and follow the manufacturer's directions.
2. Clean the Case Cart with the grain of the Case Cart panel.

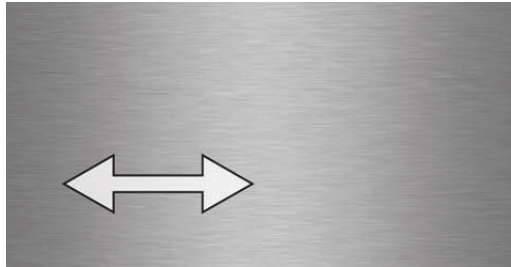

### Decals or Printed Labels:

3. Use distilled water and a mild detergent applied with a lint-free cloth. DO NOT use any chemical cleaners.

## **Cleaning Glass Doors (if applicable)**

Use a commercially prepared ammonia-free glass cleaner or use distilled water and a mild detergent applied with a lint-free cloth.

## **Case Cart Automated Cart Wash Parameters**

1. The Cart Wash Chamber must be non-pressurized.
2. Water temperatures in the range of 140°F (60°C) to 180°F (82.2°C) are allowed with an exposure period not to exceed 30 minutes.
3. Hot air drying is allowed with the temperatures not to exceed 200°F (93.3°C) and an exposure period not to exceed 15 minutes.
4. Steam sanitation is allowed with the temperature not to exceed 212°F (100°C) and an exposure period not to exceed 15 minutes.
5. Phosphoric acid-based sanitation is allowed with the concentration of phosphoric acid not to exceed 10% by volume.
6. Sodium hydroxide-based sanitation is allowed with the concentration of sodium hydroxide not to exceed 10% by volume.
7. Potassium hydroxide-based sanitation is allowed with the concentration of potassium hydroxide not to exceed 10% by volume.
8. Sodium hypochlorite, chlorine, chlorine dioxide and/or bleach based sanitation MUST be avoided.



## Replacement Parts - General

Case Cart replacement parts listed on this page have been identified by MAC Medical as serviceable by facility personnel and are available for purchase. To obtain MAC Medical certified parts and authorized services, contact your MAC Medical representative.



| Item ID | Part #          | Description  | QTY | Model                                     |
|---------|-----------------|--|-----|---|
| 1       | CC0010FM        | Bolt-on Door Latch                                       | 1   | All Closed and Vertical Handle Case Carts |
| 2       | 150966          | Bolt-on Tamper Evidence Security Hasp                    | 2   | Double Door Case Carts                    |
| 2       | 150966 & 150968 | Bolt-on Tamper Evidence Security Hasp (Pair)             | 1   | Single Door Case Carts                    |
| 3       | CC-2006R        | Bolt-on Door Hinge (Right)                               | 1   | All Closed and Vertical Handle Case Carts |
| 3       | CC-2006L        | Bolt-on Door Hinge (Left)                                | 1   | All Closed and Vertical Handle Case Carts |
| 4       | CC0003          | Door Catch   | 2   | All Closed and Vertical Handle Case Carts |
| 5       | Varies          | Bolt-on Case Cart Handle                                 | 1   | Call Customer Service                     |
| 6       | Varies          | Bolt-on Bumper Assembly                                  | 1   | Call Customer Service                     |
| 7       | H0123-SS        | 6" Jarvis Stainless Steel Swivel Directional Caster      | 3   | All Closed and Vertical Handle Case Carts |
| 7       | H0135-SS        | 6" Directional Swivel Caster                             | 3   | All Closed and Vertical Handle Case Carts |
| 7       | CC0015          | 6" Plastic Swivel Caster                                 | 2   | All Open Case Carts                       |
| 8       | CC0015DL        | 6" Plastic Swivel Caster w/ Directional Lock             | 2   | All Open Case Carts                       |
| 8       | CC0015TL        | 6" Plastic Swivel Caster w/ Total Lock                   | 2   | All Open Case Carts                       |
| 8       | H0135-LSS       | 6" Directional Locking Swivel Caster                     | 1   | All Open Case Carts                       |
| 8       | H0123-LSS       | 6" Jarvis Stainless Steel Swivel Directional Lock Caster | 1   | All Closed and Vertical Handle Case Carts |
| 9       | CC0204          | Bolt-on 8.5" x 11" Card Holder                           | 1   | All Closed and Vertical Handle Case Carts |





## Limited Lifetime Warranty

MAC Medical warrants to the original purchaser that its Proprietary Products will be free from defects in workmanship or materials under normal use and service for the life of the product, so long as owned by the original purchaser, according to the limitations set forth below.

Defective products shall be repaired or replaced at MAC Medical's option at no cost to the original purchaser provided:

1. The customer must obtain a written return authorization supplied by MAC Medical's customer service department. The product must be returned, properly packaged, with a copy of the original sales receipt and copy of the RMA authorization. Please call (877) 828-9975 or (618) 476-3550 to receive a return authorization.
2. The customer must pre-pay freight charges to and from MAC Medical and must ship merchandise properly packaged, in a way the product will not be damaged during transit to the factory. MAC Medical does not warranty any freight damage to or from the factory. It is the customer's responsibility to inspect the product for packaging damage before signing the BOL.

This warranty does not apply to products, which have been subject to abuse, misuse, accident, modification, alteration, tampering, negligence, lack of routine maintenance or misapplication; or products that have been repaired by other than MAC Medical or its authorized representatives.

This warranty does not apply to glass, fabrics, vinyl, seat coverings, cushions, padding or their stitching, gluing or installation. Component parts not manufactured by MAC Medical, such as casters, caster inserts, any components made from rubber or plastic, circuit boards, fan heaters, plumbing parts, electrical switches and other components are also excluded. For these component parts, MAC Medical will pass on the original manufacturer's warranty to MAC Medical equipment original purchasers. Please consult factory for questions regarding the warranties of these component parts. This warranty does not apply to custom fabricated products. Consult factory.

UNLESS EXPRESSLY SET FORTH IN THIS WARRANTY, THERE ARE NO OTHER WARRANTIES, WHETHER EXPRESS OR IMPLIED, OF FITNESS AND/OR MERCHANTABILITY OR ANY OTHER WARRANTY IMPLIED BY CUSTOM, USAGE OR COURSE OF DEALING.

Liability of MAC Medical under this warranty is limited to the repair and/or replacement of any products. MAC Medical specifically excludes and disclaims any responsibility for any incidental or consequential damages claimed to have arisen from any defect in workmanship or materials. No representative has any authority to change or enlarge the above warranty or MAC Medical liability. This document supersedes all previous warranty provisions.

To place an order, contact our customer service department at **618-476-3550** or **877-828-9975** or by email at [sales@macmedical.com](mailto:sales@macmedical.com)

**MADE IN THE USA**



INSPIRED  
TO BE BETTER

**Customer needs are our first priority.**

MAC Medical, Inc.  
Printed in USA  
Publication No. MAN-043 REV H  
February 2024

Information regarding this product is subject to change without prior notice.



**Corporate Office**  
200 Admiral Weinel Blvd.  
Columbia, IL 62236

**Manufacturing Plant**  
820 South Mulberry Street  
Millstadt, IL 62260

Phone: 618-476-3550 • Toll Free: 877-828-9975 • [www.macmedical.com](http://www.macmedical.com)