

D-Series Data Logging Blanket & Fluid Warming Cabinets



Model # SWC151822

DIMENSIONS

DOOR REMOVED FOR CLARITY

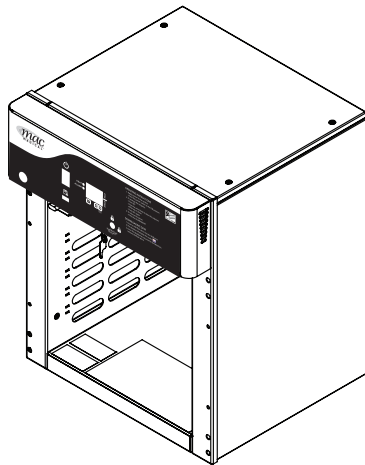

FRONT VIEW

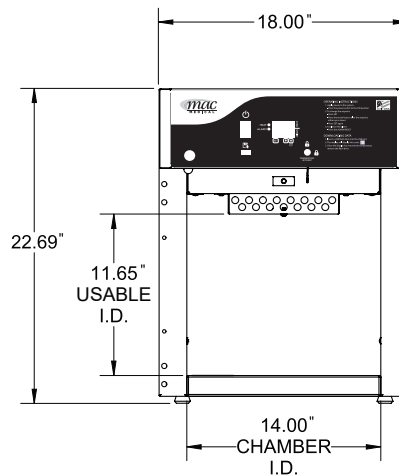

SIDE VIEW

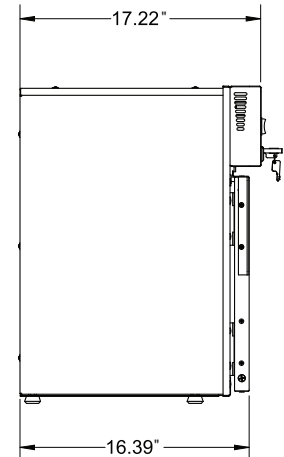

SPECIFICATIONS

Overall Size

17.25"D x 18"W x 22.5"H
(438.15mm x 457.2mm x 558.8mm)
Optional Adjustable Shelf

Chamber I.D.

14"D x 14"W x 11.63"H
(355.6mm x 355.6mm x 259.4mm)
1.30 Cubic Feet Storage
Temperature Range 90°-160° F (Tolerance +/- 1° F)

Electrical

120V, 2.08 Amp, 50/60 Hz, .25 kWh (Avg.),
853 BTU/hr (Avg.)

Door Types

Stainless Steel or Glass